



FIXED PORTABLE &
GAS DETECTOR



Portable & Fixed
Gas Detectors/
Monitoring Systems
General Catalog

We are committed to providing products that brighten the future of the environment for both people and industry.

As a leader in this field, RIKEN KEIKI continually strives in its development and manufacture of industrial gas detection equipment.

Safety and peace of mind in today's society cannot be taken for granted.

Various huge infrastructures vital to the comfort and convenience of urban life are supported by resilient systems to ensure their safety and functionality.

Similarly, in the diverse industrial fields that support social development and economic prosperity, thoroughgoing measures are required to safeguard people and the environment from the hazards and risks that may arise.

Non-Stop To avoid halting field operations

Don't Stop To avoid halting the future of research

One Stop We take our responsibilities across R&D, manufacture, and maintenance.

Next Step RIKEN KEIKI pioneers the next generation together with customers.

Portable Gas Detectors 3

Multi gas detectors

Single-component gas detectors

Fixed Gas Monitoring Systems 23

Detectors

Alarm units

Analyzers

Miscellaneous

Gas Hazards 55

What are combustible gases? 55

What are toxic gases? 56

Carbon monoxide (CO) 56

What are anoxia and hydrogen sulfide poisoning? 58

The importance of maintenance 58

Related Laws and Regulations (JAPAN) 59

Explanation of Explosion-Proof Construction 62

Detection Principle List 63

Realizing environments in which people can work with peace of

mind Introducing products needed for diverse work environments



Electronics



Oil refining and petrochemicals



Construction sites



Steel plants



Shipping and shipbuilding



Firefighting and rescue



Laboratories and universities



Volcanic and hot spring sites



Aerospace



Food industry

Portable Gas Detectors

As suggested by the name, portable gas detectors are gas detectors that can be carried or worn by workers. Unlike stationary fixed gas detectors, portable gas detectors measure and detect hazards of specific locations such as the area surrounding moving workers. These detectors help prevent all kinds of gas-related accidents by detecting at an early stage leaks of combustible gases that can build up in the air leading to explosions or leaks of toxic gases hazardous to human health, as well as by helping control the concentration of oxygen, essential to human life.

CONTENTS











Multi Gas Detectors	Portable 4-Component Gas Detector GX-3R	5
	Portable 5-Component Gas Detector GX-3R Pro	6
	Portable Multi Gas Detector GX-9000/GX-9000H	7
	Portable Multi Toxic Gas Detector SC-9000	9
	Portable 4-Component Gas Detector GX-Force	11
	Portable 6-Component Gas Detector GX-6000	13
	Portable 4-Component Gas Detector GX-2012/GX-2012GT	14
Single-Component Gas Detectors	Portable Single-Component / 2-Component Gas Detector 04 Series*	15
	Portable Single-Component / 2-Component Gas Detector GW-3 Series*	16
	Portable Combustible Gas Detector GP-1000 to prevent explosion	17
	Portable Combustible Gas Detector NC-1000 for low concentrations	17
	Portable Combustible Gas Detector NP-1000 for high concentrations	17
	Portable Gas Detector GP-03 Series	18
	Portable Gas Leak Detector SP-230 TYPE F for fluorocarbon gas	19
	Portable Gas Leak Detector SP-230 TYPE H2 for hydrogen gas	19
	Portable Gas Leak Detector SP-230 TYPE FUM for fumigation gas	20
	Portable Gas Leak Detector SP-230 TYPE SC for semiconductor material gas	20
	Optical Interferometric Gas Monitor FI-8000	21
	Formaldehyde Gas Detector FP-31	22

* Supports two-component gas detection with certain models.









Portable gas detector types and sampling methods to suit a wide range of measuring environments

Detectors use two different gas sampling methods. One is pump suction. The detector uses the suction force of its internal pump for a wide range of applications, including identifying leakage locations and checking for potential gas hazards before working inside manholes or tanks. The other is diffusion. This method eliminates the internal pump and makes it possible to make smaller and lighter units suited for real-time safety monitoring in areas surrounding workers. The present mainstream is multi gas detectors, which can simultaneously detect multiple gas types such as oxygen and the hazardous gases described above and display corresponding concentrations at the same time. Naturally, RIKEN KEIKI offers an extensive range of multi gas detectors.

Multi Gas Detectors

Diffusion type	Pump suction type
 P. 5 GX-3R	 P. 7 GX-9000
 P. 6 GX-3R Pro	 P. 7 GX-9000H
	 P. 9 SC-9000
 P. 15 CX-04	 P. 11 GX-Force
 P. 16 GW-3 (CX)	 P. 13 GX-6000
	 P. 14 GX-2012
	 P. 14 GX-2012GT

Single-Component Gas Detectors

Diffusion type	Pump suction type
 P. 15 OX-04 OX-04G CO-04 CO-04 (C-) HS-04 SC-04	 P. 17 GP-1000 NC-1000 NP-1000
 P. 16 GW-3 (O2) GW-3 (OX) GW-3 (CO) GW-3 (C-) GW-3 (HS)	 P. 19 SP-230 TYPE F TYPE H2
 P. 18 GP-03	 P. 20 SP-230 TYPE FUM TYPE SC
	 P. 21 FI-8000
	 P. 22 FP-31

Active in all fields. Compact design won't interfere with work.

Portable 4-Component Gas Detector

GX-3R



Protective cover provided as standard

Supports suction operation by attaching the RP-3R(S) pump unit (sold separately).

Main areas of use

- Electronics
- Oil refining and petrochemicals
- Construction sites
- Steel plants
- Shipping and shipbuilding
- Firefighting and rescue
- Laboratories and universities
- Volcanic and hot spring sites
- Aerospace
- Food industry
- Miscellaneous
- Medical and nursing care / Paper industry / Printing and paints / AC and refrigeration equipment
- Energy / FCV and hydrogen stations / Environment and risk assessment

Detection target gases

The detection target gases will vary depending on the particular model (sensors installed).

- 4 components ▶ Combustible gas Oxygen Carbon monoxide Hydrogen sulfide

Explosion-proof

- Explosion-proof Non-explosion-proof

Features

- One of the world's smallest, lightest portable four-component gas detectors
- Ultra-compact, lightweight design that won't interfere with work
- Incorporates high-performance new R sensor with three-year sensor warranty.
- Dust-proof, waterproof construction for peace of mind when working outdoors (protection level equivalent to IP66/68)

- EN** EN 60079-29-1 (combustible gas), EN 50104 (oxygen), EN 45544-1, EN 45544-2, EN 45544-3 (toxic gas)
- Marine** Complies with MED (European Marine Equipment Directive), JG (Ministry of Land, Infrastructure, Transport and Tourism) type approved
- JIS** Complies with JIS T 8201:2010 Oxygen deficiency indicator, Complies with JIS T 8205:2018 Hydrogen sulfide indicator/alarm.

Specifications

Model	GX-3R
Sampling method	Diffusion type (Also supports suction type if the pump unit is attached.)
Alarm type	Gas alarm, fault alarm
Alarm pattern	Lamp flashing, continuous modulating buzzer sounding, gas concentration readout blinking, vibration
Display	LCD digital (7-segment), backlight
Explosion-proof construction	Intrinsically safe explosion-proof construction
Explosion-proof class	IECEX: Ex da ia IIC T4 Ga / Ex da ia I Ma ATEX: II 1 G Ex da ia IIC T4 Ga / I M1 Ex da ia I Ma
Protection level	Equivalent to IP66/68 (2 m, 1 h)
Certifications	IECEX, ATEX, Brazil Ex, China Ex, Japan Ex, MED, JG, CE marking, JIS
Power source	Lithium ion rechargeable battery
Continuous operating time ¹	Long-life battery mode on: Approx. 40 hours (25 °C, fully charged, no alarm, no lighting) Long-life battery mode off: Approx. 25 hours (25 °C, fully charged, no alarm, no lighting)
External dimensions	Approx. 58 mm (W) × 65 mm (H) × 26 mm (D) (excluding projections)
Weight	Approx. 100 g
Operating temperature range ²	-40 to +60 °C (no sudden fluctuations)
Operating humidity range ²	0 to 95 %RH (no condensation)

¹: Varies depending on sensor type installed. Please contact RIKEN KEIKI for more information.
²: In temporary ambient conditions for approximately 15 minutes. The operating temperature and humidity ranges for continuous ambient conditions are as follows:
Temperature: -20 to +50 °C (no sudden fluctuations) / Humidity: 10 to 90 %RH (no condensation)

Detection target gas list

Detection target gas	Combustible gas (HC or CH ₄)	Oxygen (O ₂)	Carbon monoxide (CO)	Hydrogen sulfide (H ₂ S)
Detection principle	New ceramic type	Electrochemical type		
Display range	0 - 100 %LEL	0.0 - 40.0 vol%	0 - 2,000 ppm	0.0 - 200.0 ppm
Detection range	0 - 100 %LEL	0.0 - 25.0 vol%	0 - 500 ppm	0.0 - 30.0 ppm
1 digit	1 %LEL	0.1 vol%	1 ppm	0.1 ppm
Alarm setpoints (Can be set by user.)	1st 10 %LEL 2nd 50 %LEL 3rd 50 %LEL OVER 100 %LEL	L 18.0 vol% LL 18.0 vol% H 25.0 vol% OVER 40.0 vol%	1st 25 ppm 2nd 50 ppm 3rd 50 ppm TWA 25 ppm STEL 200 ppm OVER 2,000 ppm	1st 1.0 ppm 2nd 10.0 ppm 3rd 10.0 ppm TWA 1.0 ppm STEL 5.0 ppm OVER 200.0 ppm

Type list

TYPE	Detection target gas	
4-component type	TYPE A	HC or CH ₄ /O ₂ /H ₂ S/CO
	TYPE B	HC or CH ₄ /O ₂ /H ₂ S
3-component type	TYPE C	HC or CH ₄ /O ₂ /CO
	TYPE CH*	HC or CH ₄ /O ₂ /CO
2-component type	TYPE D	HC or CH ₄ /O ₂
	TYPE E	O ₂ /H ₂ S
	TYPE F	O ₂ /CO
	TYPE FH*	O ₂ /CO
	TYPE I	HC or CH ₄ /CO
	TYPE IH*	HC or CH ₄ /CO
1-component type	TYPE K	H ₂ S

* Reduced H₂ interference CO sensor

Bluetooth®-capable high-spec model

Portable 5-Component Gas Detector

GX-3R Pro



Protective cover provided as standard

Supports suction operation by attaching the RP-3R(S) pump unit (sold separately).

Main areas of use

- Electronics
- Oil refining and petrochemicals
- Construction sites
- Steel plants
- Shipping and shipbuilding
- Firefighting and rescue
- Laboratories and universities
- Volcanic and hot spring sites
- Aerospace
- Food industry
- Miscellaneous
- Medical and nursing care / Paper industry / Printing and paints / AC and refrigeration equipment
- Energy / FCV and hydrogen stations / Environment and risk assessment

Detection target gases

The detection target gases will vary depending on the particular model (sensors installed).

- 4 components + 1 component ▶ Combustible gas Oxygen Carbon monoxide Hydrogen sulfide

Additional one component can be selected from ▶ Carbon dioxide, sulfur dioxide, nitrogen dioxide, hydrogen cyanide, phosphine, and ammonia
^{*} Up to five components can be detected with the CO & H₂S dual sensor installed.

Explosion-proof

- Explosion-proof Non-explosion-proof

Features

- First Bluetooth®-capable gas detector in Japan
- Incorporates high-performance new R sensor with three-year sensor warranty.
- Operates on either rechargeable or dry batteries.
- Dust-proof, waterproof construction for peace of mind when working outdoors (protection level equivalent to IP66/68)

- EN** EN 60079-29-1 (combustible gas), EN 50104 (oxygen), EN 45544-1, EN 45544-2, EN 45544-3 (toxic gas)
- Marine** Complies with MED (European Marine Equipment Directive), JG (Ministry of Land, Infrastructure, Transport and Tourism) type approved
- JIS** Complies with JIS T 8201:2010 Oxygen deficiency indicator, Complies with JIS T 8205:2018 Hydrogen sulfide indicator/alarm.

Specifications

Model	GX-3R Pro
Sampling method	Diffusion type (Also supports suction type if the pump unit is attached.)
Alarm type	Gas alarm, fault alarm Optional: panic alarm and man down alarm
Alarm pattern	Lamp flashing, continuous modulating buzzer sounding, gas concentration readout blinking, vibration
Display	LCD digital (full-dot matrix), backlight
Display languages	Japanese, English, French, Spanish, Portuguese, German, Italian, Russian, Korean, Chinese (simplified/traditional)
Explosion-proof construction	Intrinsically safe explosion-proof construction
Explosion-proof class	IECEX: Ex da ia IIC T4 Ga / Ex da ia I Ma ATEX: II 1 G Ex da ia IIC T4 Ga / I M1 Ex da ia I Ma
Protection level	Equivalent to IP66/68 (2 m, 1 h)
Certifications	IECEX, ATEX, Brazil Ex, China Ex, Japan Ex, MED, JG, CE marking, JIS
Power source	Lithium ion rechargeable battery unit or dry battery unit (AAA alkaline batteries × 2)
Continuous operating time ¹	Long-life battery mode on: Approx. 40 hours (25 °C, fully charged, no alarm, no lighting) Long-life battery mode off: Approx. 25 hours (25 °C, fully charged, no alarm, no lighting)
External dimensions	With rechargeable battery unit: Approx. 73 mm (W) × 65 mm (H) × 26 mm (D) (excluding projections) With dry battery unit: Approx. 73 mm (W) × 65 mm (H) × 34 mm (D) (excluding projections)
Weight	Approx. 120 g (with rechargeable battery unit), approx. 140 g (with dry battery unit)
Operating temperature range ^{2, 3}	-40 to +60 °C (no sudden fluctuations)
Operating humidity range ³	0 to 95 %RH (no condensation)
Wireless specifications	Bluetooth 4.2 (Bluetooth Low Energy)

¹: Varies depending on sensor type installed. Please contact RIKEN KEIKI for more information.
²: HCN: -20 to +60 °C (no sudden fluctuations)
³: In temporary ambient conditions for approximately 15 minutes. The operating temperature and humidity ranges for continuous ambient conditions are as follows:
Temperature: -20 to +50 °C (no sudden fluctuations) / Humidity: 10 to 90 %RH (no condensation)

Detection target gas list

Detection target gas	Combustible gas (HC or CH ₄)	Oxygen (O ₂)	Carbon monoxide (CO)	Hydrogen sulfide (H ₂ S)	Sulfur dioxide (SO ₂)	Nitrogen dioxide (NO ₂)	Hydrogen cyanide (HCN)	Phosphine (PH ₃)	Ammonia (NH ₃)	Carbon dioxide (CO ₂)
Detection principle	New ceramic type	Electrochemical type							Infrared type	
Display range	0 - 100 %LEL	0.0 - 40.0 vol%	0 - 2,000 ppm	0.0 - 200.0 ppm	0.00 - 100.00 ppm	0.00 - 20.00 ppm	0.0 - 30.0 ppm	0.00 - 20.00 ppm	0.0 - 400.0 ppm	0.00 - 10.00 vol%
Detection range	0 - 100 %LEL	0.0 - 25.0 vol%	0 - 500 ppm	0.0 - 30.0 ppm	0.00 - 20.00 ppm	0.00 - 20.00 ppm	0.0 - 30.0 ppm	0.00 - 20.00 ppm	0.0 - 300.0 ppm	0.00 - 5.00 vol%
1 digit	1 %LEL	0.1 vol%	1 ppm	0.1 ppm	0.05 ppm	0.05 ppm	0.1 ppm	0.01 ppm	0.5 ppm	0.01 vol%
Alarm setpoints (Can be set by user.)	1st 10 %LEL 2nd 50 %LEL 3rd 50 %LEL OVER 100 %LEL	L 18.0 vol% LL 18.0 vol% H 25.0 vol% OVER 40.0 vol%	1st 25 ppm 2nd 50 ppm 3rd 50 ppm TWA 25 ppm STEL 200 ppm OVER 2,000 ppm	1st 1.0 ppm 2nd 10.0 ppm 3rd 10.0 ppm TWA 1.0 ppm STEL 5.0 ppm OVER 200.0 ppm	1st 2.00 ppm 2nd 5.00 ppm 3rd 5.00 ppm TWA 2.00 ppm STEL 5.00 ppm OVER 100.00 ppm	1st 3.00 ppm 2nd 6.00 ppm 3rd 6.00 ppm TWA 3.00 ppm STEL 6.00 ppm OVER 20.00 ppm	1st 4.7 ppm 2nd 9.4 ppm 3rd 9.4 ppm TWA 0.9 ppm STEL 4.5 ppm OVER 30.0 ppm	1st 0.30 ppm 2nd 0.60 ppm 3rd 0.60 ppm TWA 0.30 ppm STEL 1.00 ppm OVER 20.00 ppm	1st 25.0 ppm 2nd 35.0 ppm 3rd 35.0 ppm TWA 25.0 ppm STEL 45.0 ppm OVER 400.0 ppm	1st 0.50 vol% 2nd 3.00 vol% 3rd 3.00 vol% TWA 0.50 vol% STEL 5.00 ppm OVER 10.00 vol%

Multi Gas Detectors

Single-Component Gas Detectors

Combustible Gas Detectors

Oxygen Monitors

Compact Single-Component Gas Detectors

Toxic Gas & Special Gas Detectors

Concentration Meters

Monitors

A single unit for all kinds of marine/onshore/underground work situations

Portable Multi Gas Detector

GX-9000

(General-purpose type)



GX-9000H

(Compatible with high-concentration H₂S)



Main areas of use

- Electronics
- Oil refining and petrochemicals
- Construction sites
- Steel plants
- Shipping and shipbuilding
- Firefighting and rescue
- Laboratories and universities
- Volcanic and hot spring sites
- Aerospace
- Food industry
- Miscellaneous
- Medical and nursing care / Paper industry / Printing and paints / AC and refrigeration equipment
- Energy / FCV and hydrogen stations / Environment and risk assessment

Detection target gases

The detection target gases will vary depending on the particular model (sensors installed).

- 6 components ▶ GX-9000: Combustible gas, Oxygen, Carbon monoxide, Hydrogen sulfide, VOC, Sulfur dioxide, Ozone, Hydrogen chloride, Hydrogen cyanide, Ammonia, Chlorine, Carbon dioxide
- 4 components ▶ GX-9000H: Combustible gas, Oxygen, Carbon monoxide, Hydrogen sulfide

Explosion-proof

- Explosion-proof
- Non-explosion-proof

Features

- Incorporates next-generation high-performance R and F sensors warranted up to three years.
- Measures up to six different gas types. **GX-9000**
- Measures up to four different gas types. **GX-9000H**
- Approx. 1,000 different sensor combinations
- 1.5 m drop testing passed
- Dust-proof, waterproof construction for peace of mind when working outdoors (protection level equivalent to IP66/68)

Marine Complies with MED (European Marine Equipment Directive).

JIS Complies with JIS T 8201:2010 Oxygen deficiency indicator. Complies with JIS T 8205:2018 Hydrogen sulfide indicator/alarm.

Specifications

Model	GX-9000	GX-9000H
Sampling method	Pump suction type (Minimum suction flow rate: 0.75 L/min (open flow rate))	
Alarm type	Gas alarm, fault alarm	
Alarm pattern	Lamp flashing, continuous modulating buzzer sounding, gas concentration readout blinking	
Display	LCD digital (full-dot matrix), backlight	
Display languages	Japanese, English, Korean, Chinese (simplified/traditional), Vietnamese, Italian, Spanish, Slovak, Czech, German, Turkish, French, Portuguese, Polish, Russian	
Explosion-proof construction	Flame-proof enclosure + Intrinsicly safe explosion-proof construction (with new ceramic type sensor installed) Intrinsicly safe explosion-proof construction (without new ceramic type sensor installed)	
Explosion-proof class	IECEX: II 1 G Ex da ia IIC T4 Ga / II 1 G Ex ia IIC T4 Ga ATEX: Ex da ia IIC T4 Ga / Ex ia IIC T4 Ga	
Protection level	Equivalent to IP66/68 (2 m, 1 h)	
Certifications	IECEX, ATEX, Japan Ex, MED, EN 60079-29-1, EN 50104, CE marking, JIS	
Power source	Dedicated lithium ion battery unit (BUL-9000) or dedicated dry battery unit (AA alkaline batteries × 6) (BUD-9000)	
Continuous operating time ¹	Lithium ion battery unit: Approx. 25 hours Dry battery unit: Approx. 12 hours (25 °C, no alarm, no lighting)	Lithium ion battery unit: Approx. 35 hours Dry battery unit: Approx. 15 hours (25 °C, no alarm, no lighting)
External dimensions	Approx. 158 mm (W) × 85 mm (H) × 132 mm (D) (excluding projections)	
Weight	Approx. 1.1 Kg	Approx. 1.2 Kg
Operating temperature range ²	Approx. 15-minute temporary ambient conditions: -40 to +60 °C (no sudden fluctuations) Continuous ambient conditions: -20 to +50 °C (no sudden fluctuations)	
Operating humidity range ³	Approx. 15-minute temporary ambient conditions: 0 to 95 %RH (no condensation) Continuous ambient conditions: 10 to 90 %RH (no condensation)	
Communication specifications	USB 2.0 Type-C (for data logger/setting), Bluetooth 4.2 (Bluetooth Low Energy)	

¹: Continuous operating time: Varies depending on the sensors installed.
²: Including batteries and battery unit.
³: Operating ambient temperature/humidity range: May vary depending on the sensors installed.

• **Bluetooth® capability**
Can communicate with smartphones via Bluetooth®. Through a dedicated app, emergency alerts can be shared with remote locations in real time.

Bluetooth® and the Bluetooth® logo are registered trademarks of Bluetooth SIG, Inc. and are used by RIKEN KEIKI under license.

• Wide range of safety functions

Combustible gas conversion function (when new ceramic type sensor is installed)

Models that detect combustible gases as detection target gases can indicate direct readings of up to 27 different types of combustible gases.

* Available with HC or CH₄ model with a new ceramic type sensor installed (provided no thermal conductivity type sensor is installed)

Combustible gases conversion list

Gas name	Conversion from HC specifications	Conversion from CH ₄ specifications	Gas name	Conversion from HC specifications	Conversion from CH ₄ specifications	Gas name	Conversion from HC specifications	Conversion from CH ₄ specifications
Methane	×	—	Acetone	○	○	n-Nonane	○	○
Isobutane	—	○	Propane	×	○	Ethyl acetate	○	○
Hydrogen	○	○	Butadiene	○	○	Isopropyl alcohol	○	○
Methanol	○	○	Cyclopentane	○	○	Methyl ethyl ketone	○	○
Acetylene	○	○	Benzene	○	○	Methyl methacrylate	○	○
Ethylene	○	○	n-Hexane	○	○	Dimethyl ether	○	○
Ethane	×	○	Toluene	○	○	Methyl isobutyl ketone	○	○
Ethanol	○	○	n-Heptane	○	○	Tetrahydrofuran	○	○
Propylene	○	○	Xylene	○	○	n-Pentane	○	○

Outstanding durability



1.5 m drop testing passed

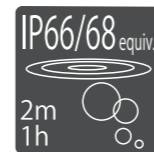

Equivalent to IP66/68 protection level



Operating temperature range -40 to +60 °C (Varies depending on gas sensors installed.)

Allows use even for large tanks!
Features high-power pump.

Includes a high-power pump allowing use even for large tanks. Gas can be aspirated from up to 45 m away using a sampling tube (sold separately).

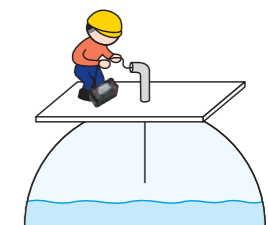

R sensors

Detection target gas	Oxygen (O ₂)	Hydrogen sulfide (H ₂ S [low concentration])	Carbon monoxide (CO)
Sensor type	ESR-X13P	ESR-A13i	ESR-A13P
Detection principle	Electrochemical type		
Display range	0 – 40.0 %	0 – 200.0 ppm	0 – 2,000 ppm
Detection range	0 – 25.0 %	0 – 100.0 ppm	0 – 500 ppm
Resolution	0.1 %	0.1 ppm	1 ppm

F sensors

Detection target gas	Methane (CH ₄)	Isobutane (HC)	Hydrogen (H ₂)	Acetylene (C ₂ H ₂)
Sensor type	NCF-6322P M	NCF-6322P		
Detection principle	New ceramic type			
Display range/detection range	0 – 100 %LEL			
Resolution	1 %LEL			

Detection target gas	Isobutane (HC)	Methane (CH ₄)	Hydrogen (H ₂)
Sensor type	TEF-7520P		
Detection principle	Thermal conductivity type		
Display range/detection range	0 – 100.0 vol%		
Resolution	0.1 vol%		

Detection target gas	Isobutane (HC)	Methane (CH ₄)
Sensor type	IRF-4345	IRF-4341
Detection principle	Non-dispersive infrared type	
Display range/detection range	0 – 100 %LEL / 100 %LEL – 100.0 vol%	
Resolution	0.5 %LEL / 0.1 vol%	

Detection target gas	Carbon dioxide (CO ₂)
Sensor type	IRF-4443
Detection principle	Non-dispersive infrared type
Display range/detection range	0 – 20.00 vol%
Resolution	0.01 vol% (0 – 5 vol%) / 0.1 vol% (5 – 20 vol%)

Detection target gas	Hydrogen sulfide (H ₂ S [high concentration])	Ammonia (NH ₃)	Chlorine (Cl ₂)	Ozone (O ₃)	Hydrogen chloride (HCl)	Sulfur dioxide (SO ₂)
Sensor type	ESF-A24R2	ESF-B242	ESF-C930	ESF-B249	ESF-A24E2	ESF-A24D4
Detection principle	Electrochemical type					
Display range/detection range	0 – 1,000 ppm	0 – 75.0 ppm	0 – 1.50 ppm	0 – 0.600 ppm	0 – 6.00 ppm	0.0 – 100.0 ppm
Resolution	1 ppm	0.5 ppm	0.01 ppm	0.005 ppm	0.05 ppm	0.1 ppm

Detection target gas	Volatile organic compounds (VOCs)		
Sensor type	PIF-001	PIF-002	PIF-003
Detection principle	Photo-ionization type (PID)		
Display range/detection range	0 – 40,000 ppb	0 – 4,000 ppm	0 – 100.0 ppm
Resolution	1 ppb (0 – 4,000 ppb) / 10 ppb (4,000 – 40,000 ppb)	0.1 ppm (0 – 400.0 ppm) / 1 ppm (400.0 – 4,000 ppm)	0.01 ppm (0 – 10.00 ppm) / 0.1 ppm (10.00 – 100.0 ppm)

* The alarm setpoints above are the default settings. Settings can be changed by the user using the configuration program.

Allows up to three different toxic gas sensors to be installed in a single unit (3-in-1).

Portable Multi Toxic Gas Detector

SC-9000



Main areas of use

- Electronics
- Oil refining and petrochemicals
- Construction sites
- Steel plants
- Shipping and shipbuilding
- Firefighting and rescue
- Laboratories and universities
- Volcanic and hot spring sites
- Aerospace
- Food industry
- Miscellaneous
- Medical and nursing care / Paper industry / Printing and paints / AC and refrigeration equipment
- Energy / FCV and hydrogen stations / Environment and risk assessment

Detection target gases

The detection target gases will vary depending on the particular model (sensors installed).

- 3 components
- Toxic gas

Explosion-proof

- Explosion-proof
- Non-explosion-proof

Features

- Detects up to three different toxic gases simultaneously.
- Up to three-year gas sensor warranty
- 1.5 m drop testing passed, protection level equivalent to IP66/68
- Bluetooth® equipped! Easy data management via smartphone
- Intrinsically safe explosion-proof construction allows use even in explosion-proof areas.
- Continuous operating time: Approx. 60 hours (for lithium ion battery model)

Specifications

Model	SC-9000
Sampling method	Pump suction type (Minimum suction flow rate: 0.75 L/min (open flow rate))
Alarm type	Gas alarm, fault alarm
Alarm pattern	Lamp flashing, continuous modulating buzzer sounding, gas concentration readout blinking
Display	LCD digital (full-dot matrix), backlight
Display languages	Japanese, English, Korean, Chinese (simplified/traditional), Vietnamese, Italian, Spanish, Slovak, Czech, German, Turkish, French, Portuguese, Polish, Russian
Explosion-proof construction	Intrinsically safe explosion-proof construction
Explosion-proof class	IECEX: Ex ia IIC T4 Ga ATEX: II 1 G E ia IIC T4 Ga
Protection level	Equivalent to IP66/68 (2 m, 1 h)
Certifications	IECEX, ATEX, Japan Ex, CE marking
Power source	Dedicated lithium ion battery unit (BUL-9000) or dedicated dry battery unit (AA alkaline batteries × 6) (BUD-9000)
Continuous operating time ^{*1}	Lithium ion battery unit: Approx. 60 hours Dry battery unit: Approx. 30 hours (25 °C, no alarm, no lighting)
External dimensions	Approx. 158 mm (W) × 85 mm (H) × 132 mm (D) (excluding projections)
Weight ^{*2}	Approx. 1.1 Kg
Operating temperature range ^{*3}	-20 to +50 °C (no sudden fluctuations)
Operating humidity range ^{*3}	20 to 90 %RH (no condensation)
Communication specifications	USB 2.0 Type-C (for data logger/setting), Bluetooth 4.2 (Bluetooth Low Energy)

*1: Continuous operating time: Varies depending on the sensors installed.

*2: Including batteries and battery unit.

*3: Operating ambient temperature/humidity range: May vary depending on the sensors installed.

Bluetooth® capability

Can communicate with smartphones via Bluetooth®.

Through a dedicated app, emergency alerts can be shared with remote locations in real time.

Bluetooth® Bluetooth® and the Bluetooth® logo are registered trademarks of Bluetooth SIG, Inc. and are used by RIKEN KEIKI under license.

Detection target gas list

Detection target gas	Ammonia (NH ₃)	Fluorine (F ₂)	Hydrogen fluoride (HF)	Chlorine (Cl ₂)	Hydrogen chloride (HCl)	Hydrogen bromide (HBr)	Chlorine trifluoride (ClF ₃)	Ozone (O ₃)
Detection range	0 – 75.0 ppm	0 – 3.00 ppm	0 – 1.50 ppm	0 – 1.50 ppm	0 – 6.00 ppm	0 – 6.00 ppm	0 – 0.300 ppm	0 – 0.600 ppm
Resolution	0.5 ppm	0.02 ppm	0.01 ppm	0.01 ppm	0.05 ppm	0.05 ppm	0.002 ppm	0.005 ppm
Alarm setpoints (1st / 2nd)	25.0 / 50.0 ppm	1.00 / 2.00 ppm	0.50 / 1.00 ppm	0.50 / 1.00 ppm	2.00 / 4.00 ppm	2.00 / 4.00 ppm	0.100 / 0.200 ppm	0.100 / 0.200 ppm
Warranty period	2 years	1 year	1 year	3 years	3 years	3 years	3 years	1 year

Detection target gas	Silane (SiH ₄)	Disilane (Si ₂ H ₆)	Phosphine (PH ₃)	Hydrogen cyanide (HCN*)	Nitrogen monoxide (NO)	Nitrogen dioxide (NO ₂)	Sulfur dioxide (SO ₂)
Detection range	0 – 15.0 ppm	0 – 15.0 ppm	0 – 1.00 ppm	0 – 15.0 ppm	0 – 100 ppm	0 – 15.0 ppm	0 – 6.00 ppm
Resolution	0.1 ppm	0.1 ppm	0.01 ppm	0.1 ppm	1 ppm	0.1 ppm	0.05 ppm
Alarm setpoints (1st / 2nd)	5.0 / 10.0 ppm	5.0 / 10.0 ppm	0.30 / 0.60 ppm	5.0 / 10.0 ppm	25 / 50 ppm	5.0 / 10.0 ppm	2.00 / 4.00 ppm
Warranty period	3 years	3 years	3 years	3 years	3 years	3 years	3 years

* There is no ATEX/IECEX model lineup. Due to export restrictions, these sensors cannot be installed in products exported outside Japan.

Allows up to three different toxic gas sensors to be installed in a single unit (3-in-1).

Previously...

Each toxic gas type required a separate gas detector.



Now covered by a single SC-9000 unit

Simply install the required gas sensors in three gas sensor slots!

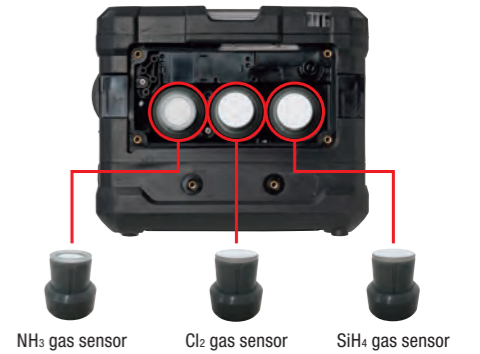

More compact than previous gas detector



Incorporates next-generation high-performance F sensors.

Next-generation high-performance gas sensors that are more compact than previous gas sensors while offering greatly improved performance and durability.

The size (volume) has been reduced to less than 1/3 of previous gas sensors.



Wide range of safety functions

Outstanding durability

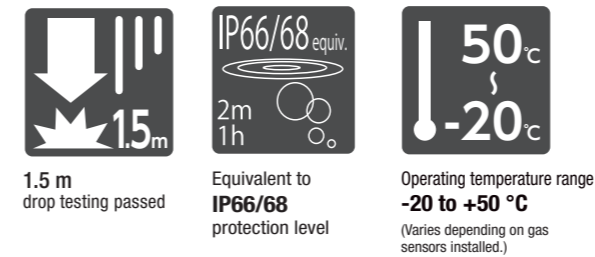

Continuous operating time: Approx. 60 hours

Twice the time of the previous gas detector to allow use for a week without recharging, even when used 8 hours a day

* For lithium ion battery model. Approx. 30 hours for dry battery model

Bluetooth® equipped! Easy data management via smartphone

Can communicate with smartphones via Bluetooth (Bluetooth Low Energy). Use the dedicated RK Link app to record measurement results. Recorded data can then be sent via email for easy management. The app can be downloaded from Google Play or App Store free of charge.



Sample app screens

Tap the snap log button to save the time and date, user, location, and measurements to the app. Saved data can then be sent via email in csv format.



Allows sharing of on-site status with remote locations.

Allows automated email transmission to registered addresses when an alarm occurs to share emergency situations remotely and in real time.

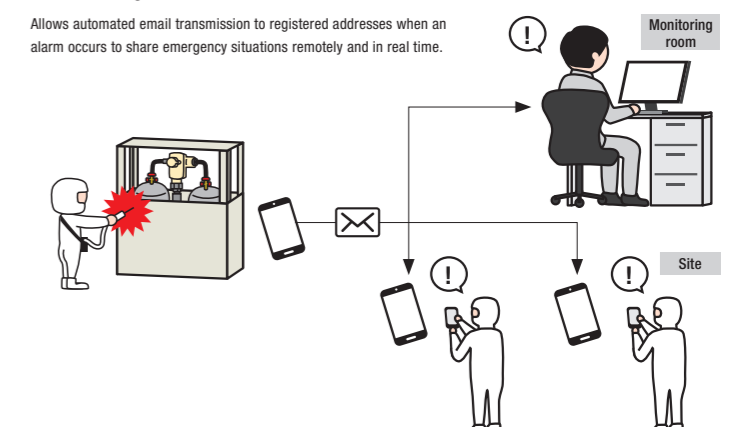

Bluetooth® and the Bluetooth® logo are registered trademarks of Bluetooth SIG, Inc. and are used by RIKEN KEIKI under license. Google Play and the Google Play logo are trademarks of Google LLC. Apple and the Apple logo are trademarks of Apple Inc. registered in the U.S. and other countries and regions. App Store is a service mark of Apple Inc. registered in the U.S. and other countries and regions.

Equipped with 30-hour operating battery for peace of mind

Portable 4-Component Gas Detector

GX-Force



Main areas of use

- Electronics
- Oil refining and petrochemicals
- Construction sites
- Steel plants
- Shipping and shipbuilding
- Firefighting and rescue
- Laboratories and universities
- Volcanic and hot spring sites
- Aerospace
- Food industry
- Miscellaneous
- Medical and nursing care / Paper industry / Printing and paints / AC and refrigeration equipment
- Energy / FCV and hydrogen stations / Environment and risk assessment

Detection target gases

The detection target gases will vary depending on the particular model (sensors installed).

- 4 components ▶ **Combustible gas** **Oxygen** **Carbon monoxide** **Hydrogen sulfide**

Explosion-proof

- Explosion-proof** **Non-explosion-proof**

Features

- Approx. 300 g lightweight easy-to-grip design
- Three-year sensor warranty
- Continuous operating time: Approx. 30 hours
- 3 m drop testing passed
- Intrinsically safe explosion-proof construction and flame-proof enclosure
- Protection level equivalent to IP67

JIS

Complies with JIS T 8201:2010 Oxygen deficiency indicator.
Complies with JIS T 8205:2018 Hydrogen sulfide indicator/alarm.
Complies with JIS T 8206:2020 Flammable gas detectors.

Specifications

Model	GX-Force
Sampling method	Pump suction type (Minimum suction flow rate: 0.35 L/min (open flow rate))
Alarm type	Gas alarm, fault alarm
Alarm pattern	Lamp flashing, continuous modulating buzzer sounding, gas concentration readout blinking, vibration
Display	LCD digital (7-segment + 14-segment + icons) with backlight
Data logger function	Maximum storage capacity: 3,600 items Interval: 5 minutes (adjustable)
Communication specifications	USB 2.0 (for data logger) * Connector: Type-C
Explosion-proof construction	Flame-proof enclosure + intrinsically safe explosion-proof construction
Explosion-proof class	IECEX: Ex da IIC T4 Ga ATEX: II 1 G Ex da IIC T4 Ga
Protection level	IP67 equivalent
Certifications	IECEX, ATEX, Brazil Ex, China Ex, Japan Ex, EN 60079-29-1, EN 50104, CE marking, JIS
Power source	Lithium ion rechargeable battery
Continuous operating time ¹	Approx. 30 hours (25 °C, fully charged, no alarm, no lighting)
External dimensions	Approx. 64 mm (W) × 173 mm (H) × 47 mm (D) (excluding projections)
Weight	Approx. 300 g
Operating temperature range ^{2,3}	-40 to +60 °C (no sudden fluctuations)
Operating humidity range ²	0 to 95 %RH (no condensation)

*1: Varies depending on sensor type installed. Please contact RIKEN KEIKI for more information.

*2: In temporary ambient conditions for approximately 15 minutes. The operating temperature and humidity ranges for continuous ambient conditions are as follows:

Temperature: -20 to +50 °C (no sudden fluctuations) / Humidity: 10 to 90 %RH (no condensation)

*3: The operating temperature range in which explosion-proof performance is maintained is as follows:

Temperature: -20 to +60 °C (no sudden fluctuations)

Type list

TYPE	Detection target gas/ Sensor	Sensor						
		HC or CH ₄ NCR-6309	O ₂ ESR-X13P	H ₂ S & CO ESR-A1DP	H ₂ S ESR-A13i	CO ESR-A13P	Reduced H ₂ interference CO ESR-A1CP	
4-component type	TYPE A	○	○	○				
3-component type	TYPE B	○	○		○			
3-component type	TYPE C	○	○			○		
3-component type	TYPE CH	○	○				○	
2-component type	TYPE D	○	○					

Detection target gas list

Detection target gas	Combustible gas (HC or CH ₄)	Oxygen (O ₂)	Carbon monoxide (CO)	Hydrogen sulfide (H ₂ S)				
Detection principle	New ceramic type	Electrochemical type						
Display range	0 – 100 %LEL	0.0 – 40.0 vol%	0 – 2,000 ppm	0.0 – 200.0 ppm				
Detection range	0 – 100 %LEL	0.0 – 25.0 vol%	0 – 500 ppm	0.0 – 30.0 ppm				
Resolution	1 %LEL	0.1 vol%	1 ppm	0.1 ppm				
Alarm setpoints (Can be set by user.)	1st	10 %LEL	L	19.5 vol%	1st	25 ppm	1st	1.0 ppm
	2nd	50 %LEL	LL	18.0 vol%	2nd	50 ppm	2nd	10.0 ppm
	3rd	50 %LEL	H	25.0 vol%	3rd	50 ppm	3rd	10.0 ppm
	OVER	100 %LEL	OVER	40.0 vol%	TWA	25 ppm	TWA	1.0 ppm
					STEL	200 ppm	STEL	5.0 ppm
				OVER	2,000 ppm	OVER	200.0 ppm	

Wide range of safety functions

Combustible gas conversion function * This function is initially disabled when shipped. Change this setting to use the function.

Eliminates the need for troublesome calculations. Allows direct readout of 27 different combustible gas types. * The setting is retained even after the power is turned off and on again.

Combustible gas conversion list

Gas name	Conversion from HC specifications	Conversion from CH ₄ specifications	Gas name	Conversion from HC specifications	Conversion from CH ₄ specifications	Gas name	Conversion from HC specifications	Conversion from CH ₄ specifications
Methane	×	—	Acetone	○	○	n-Nonane	○	○
Isobutane	—	○	Propane	×	○	Ethyl acetate	○	○
Hydrogen	○	○	Butadiene	○	○	Isopropyl alcohol	○	○
Methanol	○	○	Cyclopentane	○	○	Methyl ethyl ketone	○	○
Acetylene	○	○	Benzene	○	○	Methyl methacrylate	○	○
Ethylene	○	○	n-Hexane	○	○	Dimethyl ether	○	○
Ethane	×	○	Toluene	○	○	Methyl isobutyl ketone	○	○
Ethanol	○	○	n-Heptane	○	○	Tetrahydrofuran	○	○
Propylene	○	○	Xylene	○	○	n-Pentane	○	○

Alarm setpoint setting function

Settings can be changed/configured on the GX-Force main unit. Supports management and operation in accordance with the customer's own criteria.

Confirmation beep function

Indicates that the product is functioning normally. The buzzer sounds at preset intervals while measurement is underway.

Calibration notification function

Indicates the number of days until recommended regular maintenance when the power is turned on. Reminds the user to perform maintenance to ensure safe use.

Incorporates new R sensors for outstanding long-term stability.

The GX-Force incorporates the newly developed R sensor series. The R sensors feature dramatically improved performance over conventional sensors. The sensors are covered by a three-year warranty* for peace of mind.

* Assumes the product is inspected at least once a year.



Combustible gas

Tough construction with excellent toxicity and impact resistance



O₂

Electrochemical type with greatly improved basic characteristics



CO & H₂S

2-in-1 dual construction for compact main unit



CO

Two-sensor configuration minimizes H₂ interference

Extensive range of optional items

The optimal combination can be selected to suit requirements.

Can be fitted to allow readings to be checked even from a distance.



For measurements inside tanks

Float-type gas collector

(Tube length: approx. 8 m)
Part No.: 4384 0430 60



For measurements in specific locations within reach

Gas sampling rod and gas sampling tube

(Gas sampling tube length: approx. 75 cm)
Part No.: Gas sampling rod: 0904 0275 00
Gas sampling tube: 0914 0100 00



For measurements in high locations

Two-stage sampling rod

Part No.: 4383 0730 80



AC adapter

* The AC adapter is not supplied with the gas detector. A separate arrangement is required to recharge the gas detector.
Part No.: 2594 1342 30



Tapered nozzle

Part No.: 4126 4948 20



Hand strap

Part No.: 0888 0605 90



Belt clip

* With two attachment screws
Part No.: 4711 9954 30



Data logger management program

* A separate USB cable (optional) is required to use this.
Part No.: 9812 0020 10



USB cable (Type-A – Type-C, 1 m)

* Required when using a data logger management program (optional).
Part No.: 2440 2728 90

Protective film (set of 5 films)

Part No.: 4777 9296 50

Portable 6-Component Gas Detector

GX-6000



Main areas of use

- Electronics
- Oil refining and petrochemicals
- Construction sites
- Steel plants
- Shipping and shipbuilding
- Firefighting and rescue
- Laboratories and universities
- Volcanic and hot spring sites
- Aerospace
- Food industry
- Miscellaneous
- Medical and nursing care / Paper industry / Printing and paints / AC and refrigeration equipment / Energy / FCV and hydrogen stations / Environment and risk assessment

Detection target gases

The detection target gases will vary depending on the particular model (sensors installed).

- 6 components
- Combustible gas
- Oxygen
- Carbon monoxide
- Hydrogen sulfide
- VOC
- Sulfur dioxide
- Nitrogen dioxide
- Hydrogen cyanide
- Ammonia
- Chlorine
- Phosphine
- Carbon dioxide

Explosion-proof

- Explosion-proof
- Non-explosion-proof

Features

- Capable of detecting up to six different gases including VOCs simultaneously with a single unit. (Select up to two smart sensors with or without a base sensor.)
- Multilingual display support (Japanese, English, French, Spanish, etc.)
- Equipped with convenient functions, including panic alarm, man down alarm, and LED flashlight
- Allows selective benzene measurement (benzene select mode).

Marine JG (Ministry of Land, Infrastructure, Transport and Tourism) type approved

Specifications

Model	GX-6000
Sampling method	Pump suction type (Minimum suction flow rate: 0.45 L/min (open flow rate))
Alarm type	Gas alarm, fault alarm, panic alarm, man down alarm (optional)*1
Alarm pattern	Lamp flashing, continuous modulating buzzer sounding, gas concentration readout, alarm detail blinking, vibration
Display	LCD digital (full-dot matrix)
Display languages	Japanese, English, French, Spanish, Portuguese, German, Italian, Russian, Korean
Explosion-proof construction	Intrinsically safe explosion-proof construction
Explosion-proof class	IECEX: Ex ia IIB T4...T3 Ga ATEX: II 1 G Ex ia IIB T4...T3 Ga
Protection level	IP67 equivalent
Certifications	IECEX, ATEX, Japan Ex, JG, CE marking
Power source	Lithium ion battery unit or dry battery unit (AA alkaline batteries × 3)
Continuous operating time	Lithium ion battery unit: Approx. 14 hours (fully charged, 25 °C, no alarm, no lighting) Dry battery unit: Approx. 8 hours (with new batteries, 25 °C, no alarm, no lighting)
External dimensions	Approx. 70 mm (W) × 201 mm (H) × 54 mm (D) (excluding projections)
Weight	Approx. 500 g (with lithium ion battery unit), approx. 450 g (with dry battery unit)
Operating temperature range	-20 to +50 °C (no sudden fluctuations)
Operating humidity range	0 to 95 %RH (no condensation)

*1: The man down alarm is normally disabled. If you need to use this feature, please contact RIKEN KEIKI.

Base sensors (Select whether to include/exclude.)

Detection target gas	Combustible gas (HC/CH ₄)	Oxygen (O ₂)	Hydrogen sulfide (H ₂ S)	Carbon monoxide (CO)
Detection principle	New ceramic type	Galvanic cell type	Electrochemical type	
Detection range	0 – 100 %LEL	0.0 – 25.0 vol%	0.0 – 30.0 ppm	0 – 150 ppm
Display range	0 – 100 %LEL	0.0 – 40.0 vol%	0.0 – 30.0 ppm	0 – 500 ppm
1 digit	1 %LEL	0.1 vol%	0.1 ppm	1 ppm

Smart sensor lineup (Select up to two.**)

Detection target gas	Volatile organic compounds (VOCs)			Sulfur dioxide (SO ₂)	Nitrogen dioxide (NO ₂)	Hydrogen cyanide (HCN)	Ammonia (NH ₃)	Chlorine (Cl ₂)	Phosphine (PH ₃)	Combustible gas (HC)	Combustible gas (CH ₄)	Carbon dioxide (CO ₂)	
Detection principle	PID type			Electrochemical type			Non-dispersive infrared type						
Detection range	0 – 40,000 ppb	0 – 4,000 ppm	VOC: 0 – 100 ppm Benzene: 0 – 50 ppm*2	0.00 – 99.90 ppm	0.00 – 20.00 ppm	0.0 – 15.0 ppm	0.0 – 400.0 ppm	0.00 – 10.00 ppm	0.00 – 20.00 ppm	0 – 100 %LEL*3	0 – 100 %LEL/100.0 vol%*3	0.00 – 10.00 vol%	0 – 10,000 ppm
Display range	0 – 40,000 ppb	0 – 4,000 ppm	VOC: 0 – 100 ppm Benzene: 0 – 50 ppm*2	0.00 – 99.90 ppm	0.00 – 20.00 ppm	0.0 – 15.0 ppm	0.0 – 400.0 ppm	0.00 – 10.00 ppm	0.00 – 20.00 ppm	0.0 – 30.0 vol%*3	0 – 100 %LEL/100.0 vol%*3	0.00 – 10.00 vol%	0 – 10,000 ppm
1 digit	Up to 4,000: 1 ppb Over 4,000: 10 ppb	Up to 400.0: 0.1 ppm Over 400: 1 ppm	Up to 10 ppm: 0.01 ppm Over 10 ppm: 0.1 ppm	0.05 ppm	0.05 ppm	0.1 ppm	0.5 ppm	0.05 ppm	0.01 ppm	1 %LEL (0.5 vol%)	1 %LEL/0.5 vol%	0.02 vol%	20 ppm

*1: Additional precautions for use may be necessary depending on the combination. Contact RIKEN KEIKI for more information.

*2: In addition to VOCs, benzene can be selectively measured using a dedicated pre-filter (sold separately).

*3: The display automatically switches to vol% when gas is detected at 100 %LEL or above.

Portable 4-Component Gas Detector

GX-2012 GX-2012GT



GX-2012



GX-2012GT

Main areas of use

- Electronics
- Oil refining and petrochemicals
- Construction sites
- Steel plants
- Shipping and shipbuilding
- Firefighting and rescue
- Laboratories and universities
- Volcanic and hot spring sites
- Aerospace
- Food industry
- Miscellaneous
- Medical and nursing care / Paper industry / Printing and paints / AC and refrigeration equipment / Energy / FCV and hydrogen stations / Environment and risk assessment

Detection target gases

The detection target gases will vary depending on the particular model (sensors installed).

- 4 components
- Combustible gas
- Oxygen
- Carbon monoxide
- Hydrogen sulfide

Explosion-proof

- Explosion-proof
- Non-explosion-proof

Features

- Supports 1 ppm hydrogen sulfide alarm setpoint (ACGIH TWA 1 ppm supported). **GX-2012**
- Features leak check mode (combustible gas). **GX-2012GT**
- Three-direction alarm lamps and two-direction alarm buzzers alert both the carrier and those in surrounding areas.
- Buzzer volume of 95 dB (A) or more can be clearly heard even in noisy factory environments.
- Can be used with either a dry battery unit or a lithium ion battery unit (sold separately).

Specifications

Model	GX-2012/GX-2012GT
Sampling method	Pump suction type (Minimum suction flow rate: 0.45 L/min (open flow rate))
Alarm type*1	Gas alarm, fault alarm
Alarm pattern	Lamp lit, continuous buzzer sounding, gas concentration readout blinking, vibration
Explosion-proof construction	Intrinsically safe explosion-proof construction
Explosion-proof class	IECEX: Ex ia IIB T4 Ga ATEX: II 1 G Ex ia IIB T4 Ga
Protection level	IP67 equivalent
Certifications	IECEX, ATEX, Japan Ex, CE marking
Power source*2	Dry battery unit (AA alkaline batteries × 3) (standard) or lithium ion battery unit (optional)
Continuous operating time	Dry battery unit: Approx. 15 hours (with new batteries, 25 °C, no alarm, no lighting) Lithium ion battery unit: Approx. 10 hours (fully charged, 25 °C, no alarm, no lighting)
External dimensions	Approx. 71 mm (W) × 173 mm (H) × 43 mm (D) (excluding projections)
Weight	Approx. 360 g
Operating temperature range	-20 to +50 °C (no sudden fluctuations)
Operating humidity range	0 to 95 %RH (no condensation)

*1: The alarm types (operations) vary slightly depending on the type.

*2: The continuous operating time will vary for the GX-2012GT depending on the mode used.

Type list (GX-2012)

TYPE	Detection target gas
5-component type	TYPE A/H CH ₄ (%LEL)/CH ₄ (vol%)/O ₂ /H ₂ S/CO
4-component type	TYPE B/H HC or CH ₄ (%LEL)/O ₂ /H ₂ S/CO
3-component type	TYPE C/H HC or CH ₄ (%LEL)/O ₂ /H ₂ S
	TYPE D HC or CH ₄ (%LEL)/O ₂ /CO
2-component type	TYPE E CH ₄ (%LEL)/CH ₄ (vol%)/O ₂
	TYPE F HC or CH ₄ (%LEL)/O ₂

Type list (GX-2012GT)

TYPE	Detection target gas
5-component type	TYPE A CH ₄ (leak)/CH ₄ (%LEL)/CH ₄ (vol%)/O ₂ /CO
4-component type	TYPE B HC or CH ₄ (leak)/HC or CH ₄ (%LEL)/O ₂ /H ₂ S
	TYPE C CH ₄ (leak)/CH ₄ (%LEL)/CH ₄ (vol%)/O ₂
3-component type	TYPE D HC or CH ₄ (leak)/HC or CH ₄ (%LEL)/O ₂

Detection target gas list

Model	GX-2012/GX-2012GT			GX-2012	GX-2012GT
Detection target gas	Oxygen (O ₂)	Combustible gas (HC or CH ₄)		Carbon monoxide (CO)	Hydrogen sulfide (H ₂ S)*1
Detection principle	Galvanic cell type	New ceramic type	Thermal conductivity type	Electrochemical type	Electrochemical type
Detection range	0.0 – 25.0 vol%	0 – 100 %LEL	Up to 100 vol%*3	0 – 150 ppm	0.0 – 30.0 ppm
Display range	0.0 – 40.0 vol%	0 – 100 %LEL/Up to 100 vol%		0 – 500 ppm	0.0 – 30.0 ppm
1 digit	0.1 vol%	1 %LEL/1 vol%		1 ppm	0.1 ppm

*1: Hydrogen sulfide (H₂S) detection is available with GX-2012 only.

*2: Combustible gas leak checking (ppm detection) is available with GX-2012GT only. (The value indicated in leak check mode is the approximate concentration.)

*3: High-concentration combustible gas (vol%) detection is available with CH₄ model only.

Incorporates new R sensors for improved functionality and durability.

Portable Single-Component / 2-Component Gas Detector

04 Series



Main areas of use

- Electronics
- Oil refining and petrochemicals
- Construction sites
- Steel plants
- Shipping and shipbuilding
- Firefighting and rescue
- Laboratories and universities
- Volcanic and hot spring sites
- Aerospace
- Food industry
- Miscellaneous
- Medical and nursing care / Paper industry / Printing and paints / AC and refrigeration equipment
- Energy / FCV and hydrogen stations / Environment and risk assessment

Detection target gases

The detection target gases will vary depending on the particular model (sensors installed).

- 2 components ▶ Oxygen, Carbon monoxide
- 1 component ▶ Oxygen, Carbon monoxide, Hydrogen sulfide, Nitrogen dioxide, Sulfur dioxide, Hydrogen cyanide, Phosphine, Ammonia, Chlorine

Explosion-proof

- Explosion-proof
- Non-explosion-proof

Features

- Reduced hydrogen interference CO-04 (C-) / With dual sensor CX-04
- Long continuous operating times
- Choice of dry battery or rechargeable battery power supply
- Improved durability (withstands 7 m drop testing.)
- Three-year sensor warranty*
- Extensive gas specification lineup with 12 models in the series
- Compact lightweight design that does not interfere with work

* One-year sensor warranty for OX-04G, SC-04 (NH3), and SC-04 (CL2)

- JIS T 8201:2010 OX-04G
- JIS T 8205:2018 HS-04

Specifications

Model	Refer to the detection target gas list.
Sampling method	Diffusion type
Alarm type	Gas alarm, fault alarm
Alarm pattern	Lamp flashing, intermittent buzzer sounding, gas concentration readout blinking, vibration
Explosion-proof construction	Intrinsically safe explosion-proof construction
Explosion-proof class	<Dry cell battery model> IECEx: Ex ia IIC T4 Ga ATEX: II 1 G Ex ia IIC T4 Ga <Rechargeable battery model> IECEx: Ex ia IIC T3 Ga ATEX: II 1 G Ex ia IIC T3 Ga
Protection level	IP66/67 equivalent
Certifications	IECEX, ATEX, China Ex, Japan Ex, CE marking, JIS
Power source	AAA alkaline or Ni-MH (eneloop) batteries × 2
External dimensions/weight	Approx. 54 mm (W) × 67 mm (H) × 24 mm (D) (excluding projections) / Approx. 93 g
Operating temperature range ¹	-40 to +60 °C (no sudden fluctuations) [excluding OX-04G, SC-04 (HCN), SC-04 (NH3) ²]
Operating humidity range ¹	0 to 95 %RH (no condensation) [excluding OX-04G ³]

¹: In temporary ambient conditions for approximately 15 minutes. The operating temperature and humidity ranges for continuous ambient conditions are as follows:
SC-04 (HCN)(NH3) Temperature: -20 to +50 °C (no sudden fluctuations) / Humidity: 10 to 90 %RH (no condensation)

²: OX-04G: -20 to +50 °C, SC-04 (HCN): -20 to +60 °C, SC-04 (NH3): -30 to +50 °C (no sudden fluctuations)

³: OX-04G: 10 to 90 %RH (no condensation)

Detection target gas list

Model	OX-04G	OX-04	HS-04	CO-04	CO-04 (C-)	CX-04
Detection target gas	Oxygen (O ₂)	Oxygen (O ₂)	Hydrogen sulfide (H ₂ S)	Carbon monoxide (CO)	Carbon monoxide (CO) (Reduced hydrogen interference)	Carbon monoxide (CO) / Oxygen (O ₂)
Detection principle	Galvanic cell type	Electrochemical type				
Display range	0.0 – 40.0 %	0.0 – 40.0 %	0.0 – 200.0 ppm	0 – 2,000 ppm	0 – 2,000 ppm	0 – 2,000 ppm / 0.0 – 40.0 vol%
Detection range	0.0 – 25.0 %	0.0 – 25.0 %	0.0 – 30.0 ppm	0 – 500 ppm	0 – 500 ppm	0 – 500 ppm / 0.0 – 25.0 vol%
Continuous operating time*	Approx. 9,000 hours Approx. 6,000 hours	Approx. 3,000 hours Approx. 2,000 hours	Approx. 9,000 hours Approx. 6,000 hours	Approx. 9,000 hours Approx. 6,000 hours	Approx. 6,200 hours Approx. 4,200 hours	Approx. 4,600 hours Approx. 3,000 hours
Model	SC-04 (SO ₂)	SC-04 (NO ₂)	SC-04 (HCN)	SC-04 (PH ₃)	SC-04 (NH ₃)	SC-04 (CL ₂)
Detection target gas	Sulfur dioxide (SO ₂)	Nitrogen dioxide (NO ₂)	Hydrogen cyanide (HCN)	Phosphine (PH ₃)	Ammonia (NH ₃)	Chlorine (Cl ₂)
Detection principle	Electrochemical type					
Display range	0.00 – 100.000 ppm	0.00 – 20.00 ppm	0.00 – 30.00 ppm	0.0 – 20.00 ppm	0.00 – 400.0 ppm	0.0 – 20.00 ppm
Detection range	0.00 – 20.00 ppm	0.00 – 20.00 ppm	0.00 – 30.00 ppm	0.0 – 20.00 ppm	0.00 – 300.0 ppm	0.0 – 10.00 ppm
Continuous operating time*	Approx. 3,000 hours Approx. 2,000 hours					

* Upper row: Dry batteries, lower row: Ni-MH batteries

Among world's smallest and lightest

Portable Single-Component / 2-Component Gas Detector

GW-3 Series



Main areas of use

- Electronics
- Oil refining and petrochemicals
- Construction sites
- Steel plants
- Shipping and shipbuilding
- Firefighting and rescue
- Laboratories and universities
- Volcanic and hot spring sites
- Aerospace
- Food industry
- Miscellaneous
- Medical and nursing care / Paper industry / Printing and paints / AC and refrigeration equipment
- Energy / FCV and hydrogen stations / Environment and risk assessment

Detection target gases

The detection target gases will vary depending on the particular model (sensors installed).

- 2 components ▶ Oxygen, Carbon monoxide
- 1 component ▶ Oxygen, Carbon monoxide, Hydrogen sulfide

Explosion-proof

- Explosion-proof
- Non-explosion-proof

Features

- Among the world's smallest, lightest portable single-component gas detectors
- Compact lightweight design that does not interfere with work
- Can be worn wristwatch-style using the accessory (wristband) provided.
- Three-year sensor warranty*
- Extensive gas specification lineup with six models in the series
- Dust-proof, waterproof construction for peace of mind when working outdoors (protection level equivalent to IP66/68 (2 m, 1 h))

* One-year sensor warranty for GW-3 (O₂) only

- JIS T 8201:2010 GW-3 (O₂)
- JIS T 8205:2018 GW-3 (HS)

Specifications

Model	Refer to the detection target gas list.
Sampling method	Diffusion type
Alarm type	Gas alarm, fault alarm
Alarm pattern	Lamp flashing, intermittent buzzer sounding, gas concentration readout blinking, vibration
Explosion-proof construction	Intrinsically safe explosion-proof construction
Explosion-proof class	IECEX: Ex ia IIC T4 Ga ATEX: II 1 G Ex ia IIC T4 Ga
Protection level	Equivalent to IP66/68 (2 m, 1 h)
Certifications	IECEX, ATEX, China Ex, Japan Ex, CE marking, JIS
Power source	CR2450 coin type lithium ion battery
Continuous operating time	Approx. 4,000 hours [GW-3 (O ₂)/GW-3 (HS)/GW-3 (CO)], approx. 2,000 hours [GW-3 (OX)/GW-3 (CX)], approx. 2,500 hours [GW-3 (C-)]
External dimensions	Approx. 63 mm (W) × 42 mm (H) × 22 mm (D) (excluding projections)
Weight	Approx. 45 g
Operating temperature range	-20 to +50 °C (no sudden fluctuations) [GW-3 (O ₂)], -20 to +60 °C (no sudden fluctuations) ¹ [GW-3 (OX)/GW-3 (HS)/GW-3 (CO)/GW-3 (C-)/GW-3 (CX)]
Operating humidity range	10 to 90 %RH (no condensation) [GW-3 (O ₂)], 0 to 95 %RH (no condensation) ² [GW-3 (OX)/GW-3 (HS)/GW-3 (CO)/GW-3 (C-)/GW-3 (CX)]

¹: In temporary ambient conditions for approximately 15 minutes. The operating temperature range for continuous ambient conditions is as follows: Temperature: -20 to +50 °C (no sudden fluctuations)

²: In temporary ambient conditions for approximately 15 minutes. The operating humidity range for continuous ambient conditions is as follows: Humidity: 10 to 90 %RH (no condensation)

Detection target gas list

Model	GW-3 (O ₂)	GW-3 (OX)	GW-3 (HS)	GW-3 (CO)	GW-3 (C-)	GW-3 (CX)
Detection target gas	Oxygen (O ₂)	Oxygen (O ₂)	Hydrogen sulfide (H ₂ S)	Carbon monoxide (CO)	Carbon monoxide (CO) (Hydrogen interference reduction)	Carbon monoxide (CO) / Oxygen (O ₂)
Detection principle	Galvanic cell type	Electrochemical type				
Display range	0.0 – 40.0 vol%	0.0 – 40.0 vol%	0.0 – 200.0 ppm	0 – 2,000 ppm	0 – 2,000 ppm	0 – 2,000 ppm / 0.0 – 40.0 vol%
Detection range	0.0 – 25.0 vol%	0.0 – 25.0 vol%	0.0 – 30.0 ppm	0 – 500 ppm	0 – 500 ppm	0 – 500 ppm / 0.0 – 25.0 vol%
1 digit	0.1 vol%	0.1 vol%	0.1 ppm (0.0 – 30.0 ppm) 1.0 ppm (30.0 – 200.0 ppm)	1 ppm (0 – 300 ppm) 10 ppm (300 – 2,000 ppm)	1 ppm (0 – 300 ppm) 10 ppm (300 – 2,000 ppm)	1 ppm (0 – 300 ppm) 10 ppm (300 – 2,000 ppm) / 0.1 vol%
Alarm setpoints	L 18.0 vol% LL 18.0 vol% H 25.0 vol%	L 18.0 vol% LL 18.0 vol% H 25.0 vol%	1st 1.0 ppm 2nd 10.0 ppm 3rd 10.0 ppm TWA 1.0 ppm STEL 5.0 ppm	1st 50 ppm 2nd 150 ppm 3rd 150 ppm Cumulative 150 ppm STEL 200 ppm	1st 50 ppm 2nd 150 ppm 3rd 150 ppm Cumulative 150 ppm STEL 200 ppm	1st 50 ppm 2nd 150 ppm 3rd 150 ppm Cumulative 150 ppm STEL 200 ppm / L 18.0 vol% LL 18.0 vol% H 25.0 vol%

Portable combustible gas detector series

Portable Combustible Gas Detector

GP-1000

to prevent explosion

NC-1000

for low concentrations

NP-1000

for high concentrations



Main areas of use

Electronics	Oil refining and petrochemicals	Construction sites	Steel plants	Shipping and shipbuilding*
Firefighting and rescue	Laboratories and universities	Volcanic and hot spring sites	Aerospace	Food industry
Miscellaneous	Medical and nursing care / Paper industry / Printing and paints / AC and refrigeration equipment Energy / FCV and hydrogen stations* / Environment and risk assessment			

◆1: GP-1000/NC-1000 ◆2: NC-1000

Detection target gases

1 component ▶ Combustible gas

Explosion-proof

Explosion-proof Non-explosion-proof

Features

- Incorporates a detection gas type switching function to detect 25 different combustible gases (methane, hydrogen, benzene, toluene, xylene, etc.) with a single unit **GP-1000 NC-1000**
- Includes a pump booster feature to provide suction force even over long distances. (Suction flow rate: 0.3 L/min ⇒ 0.6 L/min)
- A cartridge-type filter (sold separately) can be attached to the standard probe. (Example filter types: for hydrogen sulfide removal, for silicon removal)
- Capable of measuring various combustible gases at ppm concentrations **NC-1000**
- The range display switches automatically (between Low and High) to suit the measurements. **NC-1000**
- Capable of measuring gases in N₂ or CO₂ in units of vol% **NP-1000**
- Select a base gas from air, nitrogen, or carbon dioxide. **NP-1000**
- Incorporates a measurement target gas type switching function to detect five different gas types (methane, propane, isobutane, argon, and helium) with a single unit. **NP-1000**

Marine JG (Ministry of Land, Infrastructure, Transport and Tourism) type approved **GP-1000**

Specifications

Model	GP-1000	NC-1000	NP-1000
Sampling method	Pump suction type (Minimum suction flow rate: 0.3 L/min for Low setting, 0.6 L/min for High setting)		
Detection target gas	Refer to the detection target gas list (page 18).		
Detection principle	New ceramic type		Thermal conductivity type
Detection range	0 – 100 %LEL	0 – 10,000 ppm	0 – 100 vol%
Alarm setpoints (Can be set by user.)	1st 10 %LEL 2nd 50 %LEL	1st 250 ppm 2nd 500 ppm	—
Alarm type ¹⁾	Gas alarm, fault alarm		Gas alarm (standard off setting), fault alarm
Alarm pattern	Lamp flashing, intermittent buzzer sounding, detail display		
Display	LCD digital (7-segment + symbols + bar meter)		
Explosion-proof construction	Intrinsically safe explosion-proof construction		
Explosion-proof class	IECEX: Ex ia IIC/IIB T4 Ga ATEX: II 1 G Ex ia IIC/IIB T4 Ga		
Protection level	IP67 equivalent		
Certifications	IECEX, ATEX, Japan Ex, JG, CE marking		IECEX, ATEX, Japan Ex, CE marking
Power source	AA alkaline batteries × 4		
Continuous operating time	Approx. 20 hours or more (with new batteries, 25 °C, no alarm, no lighting)	HC model: Approx. 20 hours, CH ₄ model: Approx. 15 hours (with new batteries, 25 °C, no alarm, no lighting)	Approx. 30 hours (with new batteries, 25 °C, no alarm, no lighting)
External dimensions	Approx. 80 mm (W) × 124 mm (H) × 36 mm (D) (excluding projections)		
Weight	Approx. 260 g (excluding dry batteries)		
Operating temperature range	-20 to +50 °C (no sudden fluctuations)		
Operating humidity range	0 to 95 %RH (no condensation)		

*1: Alarm can be enabled/disabled (disabled by default) and alarm setpoints can be set by user for NP-1000.

GP-1000/NC-1000 detection target gas list

Detection target gas	Methane (CH ₄)	Isobutane (i-C ₄ H ₁₀)	Hydrogen (H ₂)	Methanol (CH ₃ OH)	Acetylene (C ₂ H ₂)	Ethylene (C ₂ H ₄)	Ethane (C ₂ H ₆)	Ethanol (C ₂ H ₅ OH)	Propylene (C ₃ H ₆)	Acetone (C ₃ H ₆ O)	Propane (C ₃ H ₈)	Butadiene (C ₄ H ₆)	Cyclopentane (C ₅ H ₁₀)
Lower explosive limit LEL	5.0 vol%	1.8 vol%	4.0 vol%	5.5 vol%	1.5 vol%	2.7 vol%	3.0 vol%	3.3 vol%	2.0 vol%	2.15 vol%	2.0 vol%	1.1 vol%	1.4 vol%
Converted from methane	—	○	○	○	○	○	○	○	○	○	○	○	○
Converted from isobutane	×	—	○	○	○	○	×	○	○	○	×	○	○

Detection target gas	Benzene (C ₆ H ₆)	n-Hexane (n-C ₆ H ₁₄)	Toluene (C ₇ H ₈)	Heptane (n-C ₇ H ₁₆)	Xylene (C ₈ H ₁₀)	Ethyl acetate (EtAc)	IPA (IPA)	MEK (MEK)	Methyl methacrylate (MMA)	Dimethyl ether (DME)	Methyl isobutyl ketone (MIBK)	Tetrahydrofuran (THF)
Lower explosive limit LEL	1.2 vol%	1.2 vol%	1.2 vol%	1.1 vol%	1.0 vol%	2.1 vol%	2.0 vol%	1.8 vol%	1.7 vol%	3.0 vol%	1.2 vol%	2.0 vol%
Converted from methane	○	○	○	○	○	○	○	○	○	○	○	○
Converted from isobutane	○	○	○	○	○	○	○	○	○	○	○	○

* Parameters such as alarm accuracy and response time are checked using only calibration gas.

* For calibration with gases other than methane or isobutane, please contact RIKEN KEIKI.

* Note that the detection gas type cannot be switched after calibrating with a gas other than methane or isobutane.

NP-1000 detection target gas list

Detection target gas	Methane (CH ₄)	Propane (C ₃ H ₈)	Isobutane (i-C ₄ H ₁₀)	Argon (Ar)	Helium (He)	Hydrogen (H ₂)
Lower explosive limit LEL	5.0 vol%	2.1 vol%	1.8 vol%	—	—	4.0 vol%
Converted from methane	—	○	○	○	○	○
Converted from isobutane	○	○	—	○	○	○

* When used for hydrogen detection, the unit becomes a dedicated hydrogen detector. The conversion function is not available for other gases.

NP-1000 base gas list

Detection target gas	Air	Nitrogen (N ₂)	Carbon dioxide (CO ₂)
Lower explosive limit LEL	—	—	—
Converted from methane	○	○	○
Converted from isobutane	○	○	○

Compact combustible gas detector

Portable Gas Detector

GP-03



Main areas of use

Electronics	Oil refining and petrochemicals	Construction sites	Steel plants	Shipping and shipbuilding
Firefighting and rescue	Laboratories and universities	Volcanic and hot spring sites	Aerospace	Food industry
Miscellaneous	Medical and nursing care / Paper industry / Printing and paints / AC and refrigeration equipment Energy / FCV and hydrogen stations / Environment and risk assessment			

Detection target gases

1 component ▶ Combustible gas

Explosion-proof

Explosion-proof Non-explosion-proof

Features

- The product now includes rechargeable battery specifications for repeated use.
- Standard protective cover protects the main unit from scratches, dirt, and impact.
- Compact lightweight design that does not interfere with work
- Intrinsically safe explosion-proof construction allows use in hazardous locations.

Specifications

Model	GP-03
Sampling method	Diffusion type
Detection target gas	Combustible gas (HC or CH ₄)
Detection principle	New ceramic type
Detection range	0 – 100 %LEL
Alarm type	Gas alarm, fault alarm
Alarm pattern	Lamp flashing, intermittent buzzer sounding, gas concentration readout blinking, vibration
Explosion-proof construction	Intrinsically safe explosion-proof construction
Explosion-proof class	IECEX: Ex ia IIB T4...T3 Ga, Ex ia I Ma ATEX: II 1 G Ex ia IIB T4...T3 Ga, I M1 Ex ia I Ma
Protection level	IP67 equivalent
Certifications	IECEX, ATEX, Japan Ex, CE marking
Power source	AAA alkaline batteries × 2 (dry battery specifications) or AAA nickel metal hydride batteries × 2 (rechargeable battery specifications)
Continuous operating time	Dry battery specifications: Approx. 35 hours (with new batteries, 25 °C, no alarm, no lighting), Rechargeable battery specifications: Approx. 30 hours (fully charged, 25 °C, no alarm, no lighting)
External dimensions/weight	Approx. 54 mm (W) × 67 mm (H) × 24 mm (D) (excluding projections)/Approx. 80 g (excluding clip)
Operating temperature/humidity range	-20 to +50 °C (no sudden fluctuations), 0 to 90 %RH (no condensation)

Enhanced usability and robustness! Explosion-proof gas leak detector

Portable Gas Leak Detector

SP-230

TYPE F for fluorocarbon gas
TYPE H2 for hydrogen gas



Features

- Features LED light and backlit button panel.
- One-push access to multiple functions
- Reliable design for use in harsh environments

Main areas of use

Electronics	Oil refining and petrochemicals	Construction sites	Steel plants*	Shipping and shipbuilding
Firefighting and rescue	Laboratories and universities	Volcanic and hot spring sites	Aerospace*	Food industry*
Miscellaneous	Medical and nursing care / Paper industry / Printing and paints / AC and refrigeration equipment* ¹ Energy / FCV and hydrogen stations* / Environment and risk assessment			

◆1: TYPE F ◆2: TYPE H2

Detection target gases

The detection target gases will vary depending on the particular model (sensors installed).

1 component ▶ Fluorocarbon gas (TYPE F)

1 component ▶ Hydrogen gas (TYPE H2)

For information on conversion gases, refer to the catalog or instruction manual.

Explosion-proof

Explosion-proof Non-explosion-proof

Specifications

Model	SP-230 (TYPE F)	SP-230 (TYPE H2)
Sampling method	Pump suction type	
Detection principle	Hot-wire semiconductor type	
Detection range	Depends on detection target gas.	
Alarm setpoints	Can be set in 5 steps.	
Alarm pattern	Lamp flashing, buzzer sounding	
Display	LCD bar meter + scale + LED	
Explosion-proof construction	Intrinsically safe explosion-proof construction	
Protection level	IP67 equivalent	
Certifications	Japan Ex, CE marking	
Power source	AA alkaline batteries × 2	
Continuous operating time	Approx. 13 hours (with new batteries, 25 °C, no alarm, no lighting)	
External dimensions/weight	Approx. 41 mm (W) × 186 mm (H) × 38 mm (D) (excluding tapered nozzle) Approx. 220 g (excluding dry batteries)	
Operating temperature/humidity range	-20 to +55 °C (no sudden fluctuations), 0 to 95 %RH (no condensation)	

Detection target gas list (TYPE F)

Detection target gas:	R600a (Isobutane)	R290a (Propane)
Freon	Freon 123	Freon 134a
	Freon 142b	Freon 22
	Freon 32	Freon 23
	Freon 407C	Freon 410A
	Freon 404A	HFO-1234yf
	Freon 507A	Freon 407A

Detection target gas list (TYPE H2)

Detection target gas:	Methane	Acetylene	Ethane
Hydrogen, methane (calibration gas: H ₂ and CH ₄ dual gas calibration)	Propane	Isobutylene	Isobutane
	Normal hexane	Freon 134a	Hydrogen
	Ethylene	Propylene	Butadiene
	Normal butane	Cyclopentane	Freon 22
	HFO-1234yf		

Fumigation gas/semiconductor material gas leak detector

Portable Gas Leak Detector

SP-230

TYPE FUM for fumigation gas
TYPE SC for semiconductor material gas



Features

- Supports seven types of fumigation gases (TYPE FUM).
- Supports 50 types of semiconductor material gases (TYPE SC).
- One-push access to multiple functions
- Reliable design for use in harsh environments

Main areas of use

Electronics	Oil refining and petrochemicals	Construction sites	Steel plants	Shipping and shipbuilding
Firefighting and rescue	Laboratories and universities	Volcanic and hot spring sites	Aerospace	Food industry
Miscellaneous	Medical and nursing care / Paper industry / Printing and paints / AC and refrigeration equipment Energy / FCV and hydrogen stations / Environment and risk assessment			

Detection target gases

The detection target gases will vary depending on the particular model (sensors installed).

1 component ▶ Fumigation gas (TYPE FUM)

1 component ▶ Semiconductor material gas (TYPE SC)

Explosion-proof

Explosion-proof Non-explosion-proof

Specifications

Model	SP-230 (TYPE FUM) / SP-230 (TYPE SC)
Sampling method	Pump suction type
Detection principle	Hot-wire semiconductor type
Detection range	Depends on detection target gas.
Alarm setpoints	Depends on detection target gas.
Alarm pattern	Lamp flashing, buzzer sounding
Protection level	IP67 equivalent
Certification	CE marking
Power source	AA alkaline batteries × 2
Continuous operating time	Approx. 13 hours (with new batteries, 25 °C, no alarm, no lighting)
External dimensions/weight	Approx. 41 mm (W) × 186 mm (H) × 38 mm (D) (excluding tapered nozzle) Approx. 220 g (excluding dry batteries)
Operating temperature/humidity range	-20 to +55 °C (no sudden fluctuations), 0 to 95 %RH (no condensation)

This product is intended for the detection of minute gas leaks, so gas concentration values are approximate.

Detection target gas list (TYPE FUM, TYPE SC)

Model	SP-230 (TYPE FUM)	SP-230 (TYPE SC)							
Detection target gas	Phosphine	Phosphine	Acetone	Arsine	Ammonia	Isobutane	Isopropyl alcohol	Carbon monoxide	Ethyl alcohol
	Methyl bromide	Ethylene	Vinyl chloride	Methyl chloride	Xylene	Ethylene oxide	Silane	Methyl bromide	Hydrogen
	Carbon disulfide ¹	Trichloroethylene	Toluene	1,2-dichloroethane	Sulfur dioxide	Propane	Freon 134a	Freon 22	Freon 32
	Methyl iodide	Normal hexane	Benzene	Formaldehyde	Methane	Methyl alcohol	Freon 410A	Hydrogen sulfide	Diborane
	Hydrogen cyanide	Germane	Hydrogen bromide	Hydrogen chloride	Freon 407C	Hydrogen selenide	Freon 410A	Freon 404A	HFO-1234yf
	Sulfuryl fluoride	Acetylene	Dichloromethane	Propylene oxide	Trans-1,2-dichloroethylene	Freon 41	Perfluorobutadiene	Carbonyl sulfide	Deuterium
	Ethylene dibromide ¹	Freon 245fa	Trans-1,3,3,3-tetrafluoropropene						

*1: Gases whose use is prohibited in Japan

• LED display for improved visibility!

Features an LED display in addition to the conventional LCD display. Indicates current gas alarm setpoints, gas concentrations, and operating status using colors and scales.



Normal



Gas alarm state

• Comprehensive functions ensure peace of mind when working in dark places.

Features an LED light to illuminate in front and a backlit button panel for easy operation. All these comprehensive functions ensure peace of mind when working in dark places.



LED light



Backlit button panel

• Frequently used operations can be accessed with a single push.



LED light on/off

The LED light at the top of the unit can be turned on and off with a single push, convenient for working in dark places.



Alarm/operation tone on/off

The alarm sound can be turned on and off with a single button. Allows smooth work even at noise-restricted sites.



Gas alarm setpoint selection

Even if work sites changes, alarm setpoints can be quickly switched, providing peace of mind.



Shortcut key assignment

Allows assignment of a frequently used function (either snap logger function or detection target gas selection) for easy access.



* Hold down for three seconds.



Includes optical interferometric sensor ideal for precise measurement of different gas concentrations.

Optical Interferometric Gas Monitor

FI-8000



Features

- A single unit can measure up to eight different gas types.
- Choice of two suction methods: Automatic suction using the built-in pump or manual suction using the hand aspirator
- Includes intermittent measurement mode (automatic suction only).
- Large LCD screen for easy viewing

Main areas of use

Electronics	Oil refining and petrochemicals	Construction sites	Steel plants	Shipping and shipbuilding
Firefighting and rescue	Laboratories and universities	Volcanic and hot spring sites	Aerospace	Food industry
Miscellaneous	Medical and nursing care / Paper industry / Printing and paints / AC and refrigeration equipment / Energy / FCV and hydrogen stations / Environment and risk assessment			

Detection target gases

1 component ▶ Anesthetic gas Fumigation gas Other gas concentration and calorific value

Explosion-proof

Explosion-proof Non-explosion-proof

Specifications

Model	FI-8000 TYPE P-□□-□□	FI-8000 TYPE A-□□-□□
Sampling method	Automatic suction using built-in pump	Manual suction using hand aspirator
Indication accuracy	±3 % of readout (under identical conditions) ¹	
Alarm type	Fault alarm	
Alarm pattern	Lamp flashing, buzzer sounding, detail display	
Display	LCD digital (7-segment numerical + symbols + 20-segment alphabetic × 2 rows)	
Explosion-proof construction	Intrinsically safe explosion-proof construction	
Protection level	IP67 equivalent	
Certifications	IECEX, ATEX, Japan Ex, CE marking	
Power source	Dry battery unit (AA alkaline batteries × 3) or lithium ion battery unit	
Continuous operating time	Dry battery unit: 12 hours ² Lithium ion battery unit: 18 hours ³	Dry battery unit: 16 hours ² Lithium ion battery unit: 24 hours ³
External dimensions	Approx. 154 mm (W) × 127 mm (H) × 81 mm (D)	
Weight	Approx. 1.1 kg (with dry battery unit), approx. 1.2 kg (with lithium ion battery unit)	
Operating temperature/humidity range	-20 to +50 °C (no sudden fluctuations), 0 to 95 %RH (no condensation)	

*1: Indication accuracy varies depending on the measurement target gas.

*2: With new batteries, 25 °C, no lighting

*3: Fully charged, 25 °C, no lighting

Measurement target gases (5 mm chamber length)

Acetylene	Isobutane	Ethylene	Vinyl chloride	Chlorine	Xenon
Dimethyl ether	Hydrogen	Carbon dioxide	Normal butane	Propane	Freon 410A
Freon 22	Methyl bromide	Sulfur hexafluoride	Butane-air	Propane-air	

Measurement target gases (24 mm chamber length)

indicates anesthetic gas specification.

Isoflurane	Sevoflurane	Desflurane	Halothane	Nitrous oxide	Acetylene	Ethylene
Enflurane	Ozone	Difluoromethane	Deuterium	Hydrogen	Carbon dioxide	Neon
Propane	Helium	Methane	Natural gas or natural gas + LPG			

Measurement target gases (48 mm chamber length) indicates fumigation gas specification.

Sulfuryl fluoride	Propylene oxide	Methyl bromide	Methyl iodide	Phosphine	Hydrogen cyanide	Acetone	Ammonia	Isobutane	Isopropyl alcohol	Carbon monoxide	Ethyl alcohol	Ethyl benzene	Ethylene	Ethylene chloride	Xylene	Ethyl acetate
Butyl acetate	Oxygen	Dioxolane	Dichloroethane	Hydrogen	Styrene	Nitrogen	Tetrahydrofuran	Tetrafluoropropene	Toluene	Normal butane	Propane	Methanol	Methane	Methyl isobutyl ketone	Methyl isopropyl ketone	Methyl ethyl ketone

For easy formaldehyde measurement indoors

Formaldehyde Gas Detector

FP-31



Features

- Simply set the detection TAB on the main unit to begin measurement.
- Large, easy-to-read digital display allows direct reading of concentrations.
- Incorporates self-diagnosis function that indicates the timing for battery replacement or poor pump connections via buzzer and visual display.
- High accuracy with minimal interference effects

Main areas of use

Electronics	Oil refining and petrochemicals	Construction sites	Steel plants	Shipping and shipbuilding
Firefighting and rescue	Laboratories and universities	Volcanic and hot spring sites	Aerospace	Food industry
Miscellaneous	Medical and nursing care / Paper industry / Printing and paints / AC and refrigeration equipment / Energy / FCV and hydrogen stations / Environment and risk assessment			

Detection target gases

1 component ▶ Formaldehyde

Explosion-proof

Explosion-proof Non-explosion-proof

Specifications

Model	FP-31
Sampling method	Pump suction type/Time accumulation measurement (Suction flow rate: 0.5 L/min)
Alarm type	Fault alarm
Alarm pattern	Buzzer sounding, detail display
Display	LCD digital display
Certification	CE marking
Power source	AA alkaline batteries × 4
Continuous operating time	Approx. 12 hours (with new batteries, 20 °C, no alarm, no lighting)
External dimensions/weight	Approx. 80 mm (W) × 150 mm (H) × 40 mm (D) (excluding projections)/ Approx. 250 g (excluding dry batteries)
Operating temperature/humidity range	-10 to +40 °C (no sudden fluctuations), 0 to 90 %RH (no condensation) ¹

*1: The operating temperature and humidity ranges for detection TABs are indicated on each detection TAB.

Detection target gas list

Detection target gas	Formaldehyde (HCHO)	
	Photoelectric photometry	
Detection principle	Photoelectric photometry	
Detection range	TAB No. 008	TAB No. 009
	0.000 – 0.400 ppm (Displayed "<0.01" below 0.015 ppm)	0.00 – 1.00 ppm (Displayed "<0.02" below 0.02 ppm)
1 digit	0.005 ppm	0.01 ppm
Measurement time	1,800 seconds (30 minutes)	900 seconds (15 minutes)

Use TAB No. 008 (0 – 0.4 ppm) to detect formaldehyde in accordance with WHO indoor concentration guidelines (0.08 ppm/100 µg/m³ for 30-minute mean value).

FIXED GAS DETECTORS

Fixed Gas Monitoring Systems

CONTENTS

Detectors	Multi Gas Detector for Semiconductor Factories GD-84D-EX Series	25
	Smart Transmitter/Gas Detector GD-70D Series	27
	C ₄ F ₆ /C ₂ F ₆ /COS Gas Detector TP-70DG II	28
	Transportable Gas Detector TP-70D/TP-70DG	28
	Gas Detector with Signal Converter SD-3 Series	29
	Combustible Gas/Toxic Gas Smart Transmitter/Gas Detector SD-1 Series	31
	Combustible Gas Smart Transmitter/Gas Detector SD-1RI	31
	Combustible Gas/Toxic Gas Smart Transmitter/Gas Detector SD-1GH	31
	Hydrogen Sulfide/Carbon Monoxide Smart Transmitter/Gas Detector SD-1EC	31
	Oxygen Smart Transmitter/Gas Detector SD-10X	31
	Oxygen Detector Head GD-10X	32
	Flame-proof Furnace Gas Monitor GD-A2400	33
	SD-2500/SD-2600/SD-2700	
	Combustible Gas/Toxic Gas Detector Head GD-A80 Series.....	34
	Flame-proof Suction Type Gas Detector (Direct Transmission Type) GD-D58 Series	35
	Flame-proof Suction Type Gas Detector (Signal Converter Type) SD-D58 Series	35
	Flame-proof Pump Unit RP-D58	35
	Toxic Gas Detector Head GD-88 Series GD-K88Ai/GD-K88Di	36
	Oxygen Detector Head GD-88 Series GD-F88Ai/GD-F88Di	37
	Oxygen Detector Head GD-F3A-A/GD-F3A-SC-A GD-F4A-A/GD-F4A-SC-A	38
	Explosion-proof Calorimeter OHC-800	39
	Optical Interferometric Gas Monitor FI-900	40
	Optical Interferometric Gas Monitor FI-915	40
	Highly Sensitive Toxic Gas Monitor FP-300/FP-301	41
	C ₂ F ₆ /C ₄ F ₆ Highly Sensitive Toxic Gas Monitor FP-300AGZS	42
	AsH ₃ Highly Sensitive Toxic Gas Monitor FP-270As	42
	Infrared Type Fluorocarbon/IPA Gas Monitor RI-257	43
	Transportable Infrared Gas Monitor RI-557	43
	Infrared Type CO ₂ Monitor RI-215D	44
	600 Series Indoor Oxygen Monitor OX-600	45
	Indoor Carbon Monoxide Monitor EC-600	45
	Indoor CO ₂ Monitor RI-600	45
Alarm units	Multi-Point Indicator/Alarm Unit RM-5000 Series/ RM-590 Series	46
	Combustible Gas Detection Alarm System GP-148	47
	Single-Point Indicator/Alarm Unit RM-6000 Series	48
Miscellaneous	Gas Detection Alarm System RIKEN KEIKI Kanshiro II	49
Analyzers	Photoemission Yield Spectroscopy in Air AC-2S Series	50
	Photoemission Yield Spectroscopy in Air AC-5	51
	Photoemission Yield Spectroscopy in Air AC-3	51
	Photoelectron Spectrometer Optional Fermi Level Measuring Unit FAC-2	52
	Portable X-ray Diffractometer with Fluorescent X-ray Analyzer DF-01	52
Miscellaneous	Accessories.....	53
	Marine Gas Detection Alarm Systems.....	54

System Configuration Examples

Gas monitoring systems include those that integrate a gas detector for detecting gas and an indicator/alarm unit for indicating gas concentrations and issuing alarms into a single unit, and those that use a combination of gas detector(s) and an indicator/alarm unit. Gas detectors are broadly divided into two types. One type consists of a smart transmitter/gas detector with a gas concentration display that can be used on its own.

This type of detector is used for checking local concentrations near the detector. They can also be used in conjunction with an indicator/alarm unit to check gas concentrations from a safe distance from where the detector is located. The other type of gas detector does not include a gas concentration display and is used with an indicator/alarm unit. This type is used for checking concentrations in safe locations only, and not at the location where the gas detector is located.

Furthermore, indicator/alarm units may be either single-point units, which use one indicator/alarm unit per gas detector, or multi-point units, which are capable of monitoring a number of different gas detectors.

Systems can also be configured with centralized monitoring of signals output by various indicator/alarm units.

Installation example with an only gas detector

Standalone use of a smart transmitter/gas detector allows control of a revolving light and external buzzer.

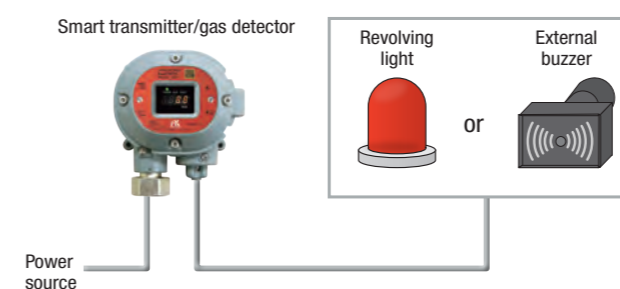

Installation example with a gas detector and indicator/alarm unit (single-point type)

A gas detector can be used in conjunction with an indicator/alarm unit to enable concentrations to be monitored at a location a safe distance away from the installation site.

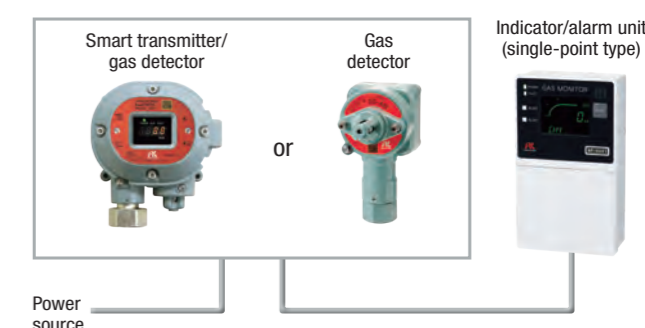

Installation example with gas detectors and an indicator/alarm unit (multi-point type)

Multiple gas detectors can be used in conjunction with an indicator/alarm unit to enable concentrations for gas detectors installed in different locations to be checked from a single location.

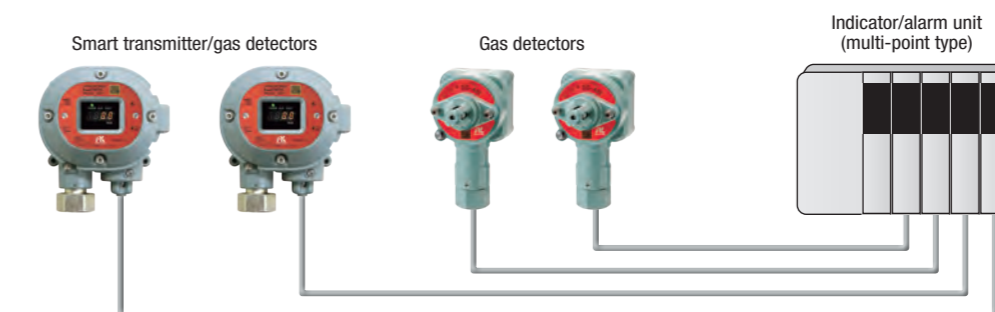

Installation example for centralized monitoring system with gas detectors and an indicator/alarm unit

Gas concentrations detected by the gas detectors can be monitored via an indicator/alarm unit using a centralized monitoring system. For smart transmitter/gas detectors, systems can also be configured by incorporating a PLC within the centralized monitoring system without the need for an indicator/alarm unit.

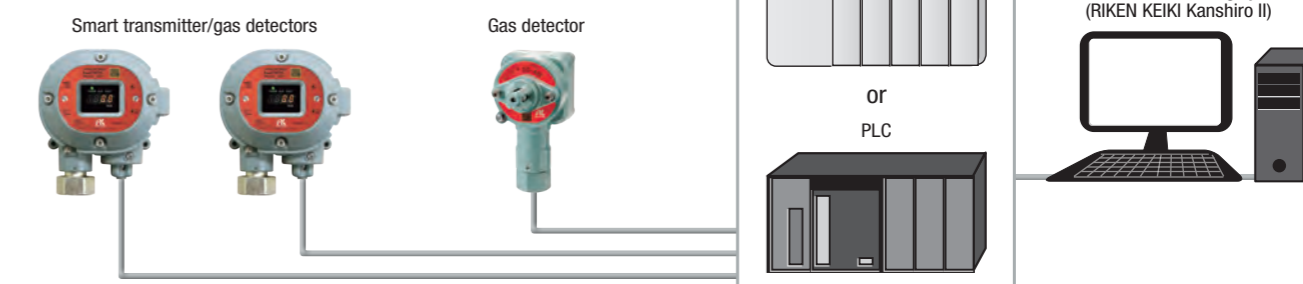

Integrates the functions of four earlier detectors into a single unit.

Multi Gas Detector for Semiconductor Factories

GD-84D-EX Series



Main areas of use

- Electronics
- Oil refining and petrochemicals
- Construction sites
- Steel plants
- Shipping and shipbuilding
- Firefighting and rescue
- Laboratories and universities
- Volcanic and hot spring sites
- Aerospace
- Food industry
- Miscellaneous
- Medical and nursing care / Paper industry / Printing and paints / AC and refrigeration equipment
- Energy / FCV and hydrogen stations / Environment and risk assessment

Detection target gases

Depends on sensors installed

Explosion-proof

Explosion-proof Non-explosion-proof

Features

- Consolidating four detectors into a single unit cuts costs by up to 1/4.
- Features a high performance pump.
- Equipped with smart self-diagnostic functions
- Ethernet (PoE) support

Specifications

Model	GD-84D-EX
Sampling method	Suction type
Detection principle	New ceramic type, semiconductor type, hot-wire semiconductor type, electrochemical type
Alarm type	Gas alarm, fault alarm
Certification	CE marking
Power source	24 V DC ± 10 % (4 to 20 mA models)
External dimensions	Approx. 150 mm (W) × 190 mm (H) × 146 mm (D) (4 to 20 mA models, EA models) (excluding projections)
Weight	Approx. 1.9 kg (4 to 20 mA models, EA models)
Operating temperature range	-10 to +40 °C (no sudden fluctuations)
Operating humidity range	20 to 90 %RH (no condensation; may vary depending on the sensors installed.)

Lineup list

Model	Communication method	Mountable sensors	Power input
GD-84D-EX-ET-EC	Ethernet only	EC only	PoE only
GD-84D-EX-ET	Ethernet only	Also compatible with sensors other than EC	PoE only
GD-84D-EX-EA-EC	Combined Ethernet/4 to 20 mA	EC only	Combined PoE/24 V DC
GD-84D-EX-EA	Combined Ethernet/4 to 20 mA	Also compatible with sensors other than EC	Combined PoE/24 V DC
GD-84D-EX-EC	4 to 20 mA only	EC only	24 V DC
GD-84D-EX	4 to 20 mA only	Also compatible with sensors other than EC	24 V DC

Detection target gas list: Electrochemical type (ESF)

Detection target gas	Nitrogen dioxide	Hydrogen chloride	Ammonia	Chlorine	Oxygen	Phosphine	Silane	Disilane	Sulfur dioxide
Display name	NO ₂	HCL	NH ₃	CL ₂	O ₂	PH ₃	SiH ₄	Si ₂ H ₆	SO ₂
Detection range	0 – 15 ppm	0 – 6 ppm	0 – 75 ppm	0.0 – 0.3 ppm	0 – 25 %	0 – 1 ppm	0 – 15 ppm	0 – 15 ppm	0 – 6 ppm
Alarm setpoint	5 ppm	2 ppm	25 ppm	0.1 ppm	18 %	0.3 ppm	5 ppm	5 ppm	2 ppm
Acceptable concentration (ACGIH)	0.2 ppm	2 ppm	25 ppm	0.1 ppm	—	0.05 ppm	5 ppm	—	0.25 ppm

Detection target gas	Nitrogen monoxide	Hydrogen bromide	Diethylamine	Dimethylamine	Ethylmethylamine	Fluorine	Hydrogen fluoride	Ozone	Chlorine trifluoride
Display name	NO	HBr	DEA	DMA	EMA	F ₂	HF	O ₃	CLF ₃
Detection range	0 – 100 ppm	0 – 6 ppm	0 – 15 ppm	0 – 15 ppm	0 – 15 ppm	0 – 3 ppm	0.0 – 1.5 ppm	0.0 – 0.6 ppm	0.0 – 0.3 ppm
Alarm setpoint	25 ppm	2 ppm	5 ppm	5 ppm	5 ppm	1 ppm	0.5 ppm	0.2 ppm	0.1 ppm
Acceptable concentration (ACGIH)	25 ppm	2 ppm	5 ppm	5 ppm	5 ppm	0.1 ppm	0.5 ppm	0.2 ppm (< 2 h)	0.1 ppm

Detection target gas list: Hot-wire semiconductor type (SHF)

Detection target gas	Freon 41 (CH3F)	Freon 32 (CH2F2)	Isopropyl alcohol	Deuterium	Hydrogen
Display name	R-41	R-32	IPA	D ₂	H ₂
Detection range	0 – 2,000 ppm	0 – 2,000 ppm	0 – 2,000 ppm	0 – 2,000 ppm	0 – 2,000 ppm
Alarm setpoint	500 ppm	500 ppm	500 ppm	500 ppm	500 ppm
Acceptable concentration (ACGIH)	—	—	200 ppm	—	—

Detection target gas list: New ceramic type (NCF)

Detection target gas	Methane	Hydrogen	Isopropyl alcohol
Display name	CH ₄	H ₂	IPA
Detection range	0 – 100 %LEL	0 – 100 %LEL	0 – 100 %LEL
Alarm setpoint	25 %LEL	25 %LEL	25 %LEL
LEL	5.0 vol%	4.0 vol%	2.0 vol%

Detection target gas list: Semiconductor type (SGF)

Detection target gas	Methane	Carbonyl sulfide
Display name	CH ₄	COS
Detection range	0 – 2,000 ppm	0 – 2,000 ppm
Alarm setpoints	500 ppm	500 ppm
Acceptable concentration (ACGIH)	—	5 ppm

- Full-dot matrix LCD for legibility! Simultaneous four-component display



- Features high performance pump.

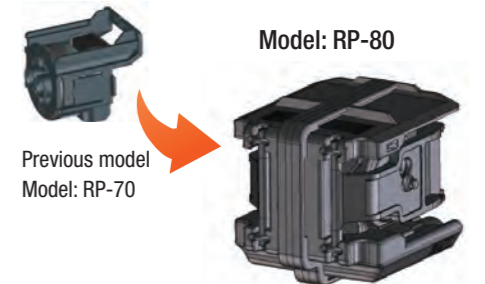

- Reduced vibration** Two diaphragms to cancel vibration
- Surge prevention** Buffer provided inside chamber
- Smaller environmental footprint** Eliminates adhesives and bolts (and nuts) for easier recycling.
- Reduced noise** Revised valve configuration
- Redundancy** Twin pump → Suction possible even with one failed pump

- Features next-generation high-performance F sensors.

The high-performance F sensors feature significantly improved self-diagnostic functions. (See table at right.) In addition to sensor types for the 18 different major toxic gases, the lineup includes gas sensors for 67 distinct combustible gases. 1/10 the size of previous sensors; new sensors also offer equivalent or superior interference resistance.

Self-diagnostic functions

Name	Applicable principles	Details
Service life expiration warning	All principles	An alarm is issued after three years from the start of use.
Degradation diagnostic warning (sensor output abnormality)	NCF SHF SGF	An alarm is issued when the value of the drift from the initial sensor output (in air) exceeds the threshold.
Degradation diagnostic warning (fluid shortage detection)	ESF	An alarm is issued when the fluid resistance between electrodes exceeds the threshold.
Life assessment warning	All principles	An alarm is issued when the span reserve estimated based on the calibration history reaches zero.
Vitality (span reserve)	All principles	The sensor reserve is displayed as 0 to 100 when a known concentration of gas is allowed to flow.

Sensor lineup



- Communication methods

Ethernet (PoE) method

The PoE HUB allows power supply via LAN cable, significantly reducing installation costs. It also allows operators to view the operational status of the detector via a web browser.

[User mode]

Enables checking of basic information such as gas names and alarm setpoints, as well as alarm history and communication history.

[Administrator mode]

Apart from checking basic data, you can also change settings for alarm setpoints or the network, run calibrations, alarm tests and fault alarm tests, reset alarms, and set INHIBIT.

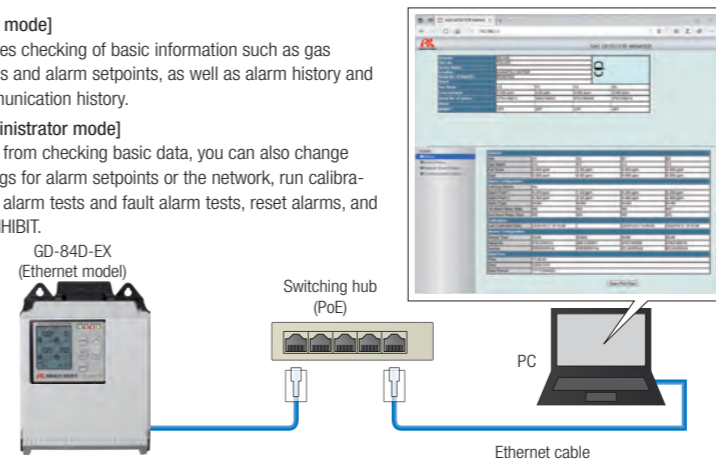

Analog 4 to 20 mA DC

Gas concentration data is output via a general instrumentation signal (4 to 20 mA DC). This allows greater flexibility in system configuration.

Pattern 1

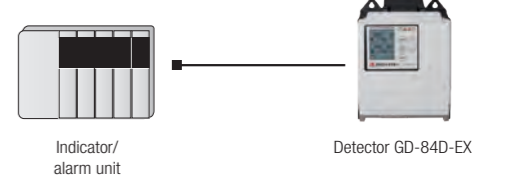

Pattern 2

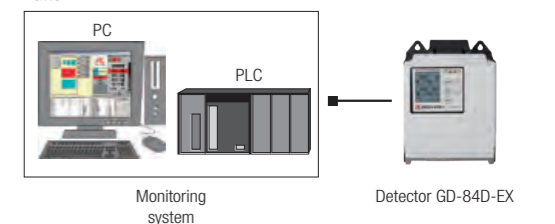

* Certain restrictions apply regarding combinations of sensors installed. * Refer to "TLVs and Bels 2022" for acceptable concentrations specified by the ACGIH (American Conference of Government Industrial Hygienists).
* For more information on other gases, contact RIKEN KEIKI.

Smart Transmitter/Gas Detector

GD-70D Series



Main areas of use

- Electronics
- Oil refining and petrochemicals
- Construction sites
- Steel plants
- Shipping and shipbuilding
- Firefighting and rescue
- Laboratories and universities
- Volcanic and hot spring sites
- Aerospace
- Food industry
- Miscellaneous
- Medical and nursing care / Paper industry / Printing and paints / AC and refrigeration equipment
- Energy / FCV and hydrogen stations / Environment and risk assessment

Detection target gases

Depends on sensor installed

Explosion-proof

Explosion-proof Non-explosion-proof

Features

- Uses universal design independent of detection principle to allow shared use of the main unit.
- Power consumption reduced to 20 % of previous model (for the electrochemical type)
- Uses reusable parts.
- Allows recycling of constituent materials to reduce environmental impact.
- Design complies with various international standards.

Specifications

Model	GD-70D
Detection principle	Depends on sensor unit installed (same for all sensor units)
Communication method	4 to 20 mA DC (non-insulated, load resistance 300 Ω or less)*
Detection method	Pump suction type (0.5 L/min ± 10 %)
Display	Character LCD (white backlight) Digital and bar meter display: Gas concentration, alarm setpoint Digital and character LCD: Flow rate, communication, pyrolyzer connection, units, gas name, maintenance, inhibit, concentration
Alarm indications	First alarm: Red LED Second alarm: Red LED Fault alarm: Yellow LED, fault detail display
External output	Gas concentration signal, gas alarm contact, fault alarm contact
Self-diagnostic functions	System abnormality, sensor abnormality, flow abnormality, communication abnormality, pyrolyzer unit abnormality
Data logger functions	Event history, calibration history, alarm trend history
Operating temperature range	0 to +40 °C (no sudden fluctuations)
Operating humidity range	30 to 70 %RH (no condensation) * May vary depending on the sensor installed.
Settings/operations	Performed using the front panel of the main unit
Certification	CE marking
Power source	24 V DC ± 10 %
External dimensions	Approx. 70 mm (W) × 120 mm (H) × 145 mm (D) (excluding projections)
Weight	Approx. 0.9 kg (including sensor unit)

* For information on other communication methods, please contact RIKEN KEIKI.

For nitrous oxide detection



Detection target gas list

Detection target gas	Phosphine	Diborane	Silane	Nitrogen trifluoride	Hydrogen chloride	Hydrogen fluoride	Tetraethoxysilane	Hydrogen bromide	Chlorine	Fluorine
Display name	PH ₃	B ₂ H ₆	SiH ₄	NF ₃	HCl	HF	TEOS	HBr	Cl ₂	F ₂
Detection range	0 – 0.15 ppm	0.0 – 0.3 ppm	0 – 15 ppm	0 – 30 ppm	0 – 6 ppm	0.0 – 1.5 ppm	0 – 15 ppm	0 – 6 ppm	0.0 – 0.3 ppm	0 – 3 ppm
Alarm setpoint	0.05 ppm	0.1 ppm	5 ppm	10 ppm	2 ppm	0.5 ppm	10 ppm	2 ppm	0.1 ppm	1 ppm
Acceptable concentration (ACGIH)	0.05 ppm	0.1 ppm	5 ppm	10 ppm	2 ppm	0.5 ppm	10 ppm	2 ppm	0.1 ppm	0.1 ppm

Detection target gas	Chlorine trifluoride	Ozone	Nitrogen monoxide	Arsine	Carbon monoxide	Ammonia	Disilane	Germane	Hydrogen selenide	Bromine
Display name	ClF ₃	O ₃	NO	AsH ₃	CO	NH ₃	Si ₂ H ₆	GeH ₄	H ₂ Se	Br ₂
Detection range	0.0 – 0.3 ppm	0.0 – 0.6 ppm	0 – 100 ppm	0 – 50 ppb	0 – 75 ppm	0 – 75 ppm	0 – 15 ppm	0.0 – 0.8 ppm	0.0 – 0.2 ppm	0 – 1 ppm
Alarm setpoint	0.1 ppm	0.2 ppm	25 ppm	10 ppb	25 ppm	25 ppm	5 ppm	0.2 ppm	0.05 ppm	0.3 ppm
Acceptable concentration (ACGIH)	0.1 ppm	0.1 ppm	25 ppm	5 ppb	25 ppm	25 ppm	—	0.2 ppm	0.05 ppm	0.1 ppm

Detection target gas	Nitrogen dioxide	Sulfur dioxide	Monomethylamine	Dimethylamine	Trimethylamine	Diethylamine	Oxygen	Hydrogen	Nitrous oxide	Hydrogen cyanide
Display name	NO ₂	SO ₂	MMIA	DMA	TMA	DEA	O ₂	H ₂	N ₂ O	HCN
Detection range	0 – 9 ppm	0 – 6 ppm	0 – 15 ppm	0 – 15 ppm	0 – 15 ppm	0 – 15 ppm	0 – 25 vol%	0 – 2,000 ppm	0 – 500 ppm	0 – 15 ppm
Alarm setpoint	3 ppm	2 ppm	5 ppm	5 ppm	5 ppm	5 ppm	18 vol%	500 ppm	50 ppm	4 ppm
Acceptable concentration (ACGIH)	0.2 ppm	0.25 ppm	5 ppm	5 ppm	5 ppm	5 ppm	—	—	50 ppm	4.7 ppm

* Refer to "TLVs and BEs 2022" for acceptable concentrations specified by the ACGIH (American Conference of Government Industrial Hygienists). * For more information on other gases, contact RIKEN KEIKI.

C₄F₆/C₅F₈/COS Gas Detector

TP-70DG II



TP-70DG II

Features

- Incorporates a pyrolyzer containing catalyst to reduce interference effects.
- Easy-to-replace sensor
- Large character LCD for easy viewing
- Features automatic flow adjustment function.

Main areas of use

- Electronics
- Oil refining and petrochemicals
- Construction sites
- Steel plants
- Shipping and shipbuilding
- Firefighting and rescue
- Laboratories and universities
- Volcanic and hot spring sites
- Aerospace
- Food industry
- Miscellaneous
- Medical and nursing care / Paper industry / Printing and paints / AC and refrigeration equipment
- Energy / FCV and hydrogen stations / Environment and risk assessment

Detection target gases

C₄F₆ C₅F₈ COS

Explosion-proof

Explosion-proof Non-explosion-proof

Specifications

Model	TP-70DG II
Sampling method	Suction type
Detection target gas	C ₄ F ₆ , C ₅ F ₈ , COS
Detection principle	Catalyst + electrochemical type
Detection range	0 – 5 ppm (C ₄ F ₆ , C ₅ F ₈) 0 – 15 ppm (COS)
Alarm setpoints	1st: 2 ppm, 2nd: 4 ppm (C ₄ F ₆ , C ₅ F ₈) 1st: 5 ppm, 2nd: 10 ppm (COS)
Alarm type	Gas alarm, fault alarm
Alarm pattern	1st: ALM1 lamp flashing or lit (red), 2nd: ALM2 lamp flashing or lit (red)
Certification	CE marking
Power source	100 to 240 V AC ± 10 %, 50/60 Hz
External dimensions	Approx. 180 mm (W) × 225 mm (H) × 285 mm (D) (excluding projections)
Weight	Approx. 6.0 kg
Operating temperature range	+20 to 40 °C (no sudden fluctuations)
Operating humidity range	40 to 70 %RH (no condensation)

For detecting special material gas leaks and monitoring environments inside factories

Transportable Gas Detector

TP-70D TP-70DG



Features

- Gas type can be changed by replacing the sensor.
- Large character LCD for easy viewing
- Automatic flow adjustment function reduces work in daily maintenance.

Main areas of use

- Electronics
- Oil refining and petrochemicals
- Construction sites
- Steel plants
- Shipping and shipbuilding
- Firefighting and rescue
- Laboratories and universities
- Volcanic and hot spring sites
- Aerospace
- Food industry
- Miscellaneous
- Medical and nursing care / Paper industry / Printing and paints / AC and refrigeration equipment
- Energy / FCV and hydrogen stations / Environment and risk assessment

Detection target gases

Depends on sensor installed

Explosion-proof

Explosion-proof Non-explosion-proof

Specifications

Model	TP-70D	TP-70DG
Sampling method	Pump suction type	
Detection target gas	Depends on sensor unit installed	NF ₃
Detection principle	Catalytic combustion type, semiconductor type, non-dispersive infrared type, electrochemical type, galvanic cell type	Electrochemical type + pyrolysis type
Concentration display	Character LCD (digital and bar meter display)	
Alarm type	Gas alarm, fault alarm	
Alarm pattern	1st: ALM1 lamp flashing or lit (red), intermittent buzzer sounding 2nd: ALM2 lamp flashing or lit (red), intermittent buzzer sounding	
Power source	100 to 240 V AC ± 10 %, 50/60 Hz	
Power consumption	Approx. 12 VA (max. 20 VA) * May vary depending on the sensor installed.	Approx. 40 VA (max. 45 VA)
External dimensions	Approx. 160 mm (W) × 210 mm (H) × 260 mm (D) (excluding projections)	
Weight	Approx. 4.3 kg	Approx. 5.4 kg
Operating temperature range	0 to +40 °C (no sudden fluctuations)	
Operating humidity range	30 to 70 %RH (no condensation) * May vary depending on the sensor installed.	30 to 70 %RH (no condensation)

Features next-generation high-performance sensors; compliant with various global standards

Gas Detector with Signal Converter

SD-3 Series



Nameplate color: Red



Blue



Yellow



Silver

Specifications

Model	Diffusion type	SD-3RI	SD-3NC	SD-3GH	SD-3GHS	SD-3SP	SD-3EC	SD-3ECS	SD-3ECB		
	Suction type	SD-3DRI	SD-3DNC	SD-3DGH	SD-3DGS	SD-3DSP	SD-3DEC	SD-3DECS	SD-3DECB		
Detection principle	Non-dispersive infrared type	New ceramic type	Semiconductor type			Hot-wire semiconductor type	Electrochemical type				
Detection target gas	Combustible gas/toxic gas/oxygen; detection range depends on detection target gas.										
Display	7-segment LED (5 digits) and 3-color lamps (red/green/yellow)										
Sampling method	Diffusion/Suction (introduced via an external unit)										
Set flow rate	0.4 to 1.5 L/min										
Gas alarm type	Two-step alarm (H-HH or L-LL), L-LL selectable with O ₂ models only										
Fault alarm/self-diagnosis	System abnormality (E-9)/sensor abnormality (E-1)										
Warnings	Sensor life assessment/clock abnormality diagnosis/communication diagnosis/sensor warning										
Gas concentration output	Standard	Gas concentration output (4 to 20 mA with HART), 4 to 20 mA DC (non-insulated, linear output), load resistance 600 Ω or less, maximum resolution 250 divisions (depends on specifications.)									
	Option	RS-485 (half duplex)									
Contact output (optional)	SPDT (2 alarms, 1 fault output operation), 250 V AC 2 A, 30 V DC 1 A (resistance load), minimum load 5 V DC 0.1 A										
Power source	24 V DC (18 to 30 V DC)										
Power consumption	Maximum 3.8 W	Maximum 4.5 W			Maximum 3.5 W		Maximum 2.8 W		Maximum 3.1 W		
Cable connectors	IECEx/ATEX: M25 × 1.5, adapters (optional): NPT3/4, NPT1/2, M20 × 1.5 Japan Ex: Pressure-resistant packing cable glands (M20 × 1.5 / M25 × 1.5) (compatible cable diameter: 6.0 to 16.0 mm)										
Operating temperature/humidity range	IECEx/ATEX: -40 to +70 °C (no sudden fluctuations), Japan Ex: -20 to +70 °C (no sudden fluctuations), 0 to 95 %RH (no condensation) In accordance with sensor specifications if restrictions apply due to sensor specifications										
Housing material	SCS14 stainless steel (equivalent to SUS316)										
Protection level	IP66/67 equivalent										
External dimensions (excluding cable gland projections)	Diffusion type	Approx. 171 mm (W) × 277 mm (H) × 127 mm (D)					Approx. 171 mm (W) × 322 mm (H) × 127 mm (D)				
	Suction type	Approx. 171 mm (W) × 289 mm (H) × 127 mm (D)					Approx. 171 mm (W) × 334 mm (H) × 127 mm (D)				
Weight (excluding cable glands)	Diffusion type	Approx. 6.7 kg					Approx. 7.3 kg				
	Suction type	Approx. 7.0 kg					Approx. 7.6 kg				
Explosion-proof construction	Flame-proof enclosure + Intrinsically safe explosion-proof construction										
Explosion-proof certifications	IECEx	Ex db IIC T6...T5 Gb	Ex db IIC T5...T4 Gb	Ex db IIC T6...T4 Gb	Ex db IIC T5...T4 Gb	Ex db IIC T4 Gb	Ex db IIC T4 Gb	Ex db ia IIC T4 Gb	Ex db ia IIC T4 Gb		
	ATEX	II 2 G Ex db IIC T6...T5 Gb	II 2 G Ex db IIC T5...T4 Gb	II 2 G Ex db IIC T6...T4 Gb	II 2 G Ex db IIC T5...T4 Gb	II 2 G Ex db IIC T4 Gb	II 2 G Ex db IIC T4 Gb	II 2 G Ex db ia IIC T4 Gb	II 2 G Ex db ia IIC T4 Gb		
Functional safety IEC 61508*	SIL2 compliant (SIL3 compliant with redundancy)					SIL2 compliant (SIL3 compliant with redundancy)					
HART Communication	HART communication (HART7), Modbus communication (RS-485)										

* Select SIL certified external units when used in conjunction with suction types. For information on target gases, refer to the F sensor list on page 5 of the product-specific catalog.

List of detection target gases by model

Model	SD-3RI	SD-3DRI	SD-3NC	SD-3DNC	SD-3GH	SD-3DGH	SD-3GHS	SD-3DGS	SD-3SP	SD-3DSP	SD-3EC	SD-3DEC	SD-3ECS	SD-3DECS	SD-3ECB	SD-3DECB	
Sampling method	Diffusion type	Suction type	Diffusion type	Suction type	Diffusion type	Suction type	Diffusion type	Suction type	Diffusion type	Suction type	Diffusion type	Suction type	Diffusion type	Suction type	Diffusion type	Suction type	
Detection principle	IRF: Non-dispersive infrared type		NCF: New ceramic type		SGF: Semiconductor type				SHF: Hot-wire semiconductor type		ESF: Electrochemical type						
Detection target gas	Combustible gas	○	○	○	○	○	○	○	○	○	○	○	○	○	○	○	
	Oxygen	○	○	○	○	○	○	○	○	○	○	○	○	○	○	○	
	Toxic gas	○	○	○	○	○	○	○	○	○	○	○	○	○	○	○	
Remarks											CS ₂ (carbon disulfide) only		H ₂ S (hydrogen sulfide) only				With EC barrier*

* Differs depending on detection target gas. For more information, refer to the F sensor list on page 5 of the product-specific catalog.

Main areas of use

Electronics	Oil refining and petrochemicals	Construction sites	Steel plants	Shipping and shipbuilding
Firefighting and rescue	Laboratories and universities	Volcanic and hot spring sites	Aerospace	Food industry
Miscellaneous	Medical and nursing care / Paper industry / Printing and paints / AC and refrigeration equipment / Energy / FCV and hydrogen stations / Environment and risk assessment			

Detection target gases

Depends on sensor installed

Explosion-proof

Explosion-proof Non-explosion-proof

Features

- Incorporates newly developed F sensor for improved functionality and performance.
- Complies with different global standards.
- Wide range of output options
- Rugged housing construction allows use even in harsh environments.
- Wide range of types to suit a variety of uses and installation environments

Features the next-generation high-performance F Sensors.

- Three-year sensor warranty * Except for certain sensors. Assumes sensor is inspected at least once a year.
- Operating temperature range: -40 to +70 °C * Except for certain sensors
- IIEC/EN performance compliance scheduled * Except for certain sensors
- Includes sensor degradation and life assessment functions.

Compatible with a wide range of toxic gases

The SD-3EC Series lineup features an intrinsically safe explosion-proof barrier integral construction (flame-proof enclosure + intrinsically safe explosion-proof construction). This eliminates the need for sintered metal in the sensor and allows detection of a wide range of highly adsorptive toxic gases.

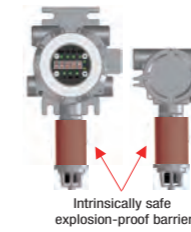

* Compatible models: SD-3ECB, SD-3DECB, GD-3ECB

Double range capability (NC type)

Double ranges in the form of low concentration (ppm) and lower explosive limit (LEL) can be detected with a single unit.

* Supports Modbus communication, but not compatible with HART communication.

* Not SIL compliant

Wide range of output options

The SD-3 Series also supports Modbus (RS-485) communication in addition to 4 to 20 mA output with HART communication. Three relay contacts are also available (ALARM1, ALARM2, and FAULT). Select any of the following three types to suit specific uses:

- ① 4 to 20 mA signal with HART communication [standard]
- ② 4 to 20 mA signal with HART communication + contacts (3c) [optional]
- ③ 4 to 20 mA signal + Modbus (RS-485) communication [optional]

Rugged housing construction allows use even in harsh environments.

- Housing material: SCS14 stainless steel (equivalent to SUS316)
- Protection level equivalent to IP66/67
- Supports wide range of operating temperatures (-40 to +70 °C)
* Japan Ex: -20 to +70 °C
- Extensive range of optional accessories: Protective cover, splash guard, lightning arrester (Japan Ex not supported), various filters, etc.



With sunshade fitted



With splash guard fitted

Order information

SD-3 ① ② (③ ④ ⑤ ⑥ ⑦ ⑧)

① Diffusion type/suction type selection	Blank Diffusion type	D Suction type (introduced via an external unit)
② Sensor type selection	RI Non-dispersive infrared type	NC New ceramic type
	GH Semiconductor type	GHS Semiconductor type (selectable with CS ₂ only)
	SP Hot-wire semiconductor type	EC Electrochemical type (selectable with CO/O ₂ only)
	ECS Electrochemical type (selectable with H ₂ S only)	ECB Electrochemical type (selectable with gases other than CO/O ₂ /H ₂ S)
③ Cable connectors (See diagram on right.)	0 Connector 1, Connector 2	1 Connector 1, Connector 2, Connector 4, Connector 5
④ Explosion-proof	1 IECEx/ATEX	2 FM (US) [Zone] ^{1,2}
	3 Japan Ex	4 cFM (Canada) [Zone] ^{1,2}
	5 —	6 Taiwan Ex (TS Mark)
	7 China Ex	

[Remote type: Main unit (SD-3SC) + Sensor unit (GD-3 Series)]

SD-3SC (③ ④ ⑤ ⑥ ⑦ ⑧)

⑤ Functional safety IEC 61508	0 N/A	1 SIL ^{1,3}
⑥ Certifications	0 N/A	1 EN performance ^{1,3}
	2 US/Canada performance ^{1,3}	3 IEC performance ^{1,3}

GD-3 ②

⑦ Range setting	0 Single range	1 Double range + 4-16 (selectable with NC only) ⁴	2 Double range + L4-20 (selectable with NC only) ⁴	3 Double range + H4-20 (selectable with NC only) ⁴
⑧ Output type selection	0 4 to 20 mA with HART	1 4 to 20 mA with HART + contacts (3c)	2 4 to 20 mA + RS-485	

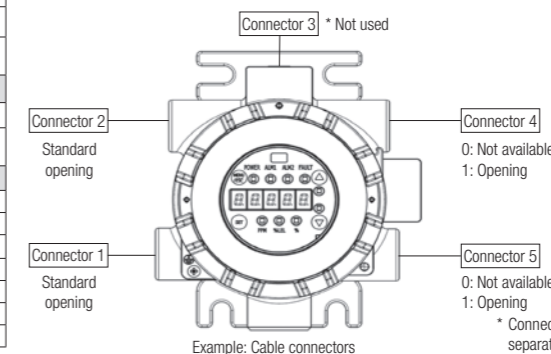

- *1: Compatibility differs depending on sensor. Contact RIKEN KEIKI for more information.
- *2: Select 2 for "⑥ Certifications" when FM (US) or cFM (Canada) is selected.
- *3: 1 to 3 cannot be selected for "⑦ Range setting" when SIL certification or individual performance is selected.
- *4: HART communication is not available when double range is selected.

* Connectors must always be blanked off with blanking plugs (sold separately) when not in use.

Standard type smart transmitter/gas detector

Combustible Gas/Toxic Gas Smart Transmitter/Gas Detector

SD-1 Series



Main areas of use

- Electronics
- Oil refining and petrochemicals
- Construction sites
- Steel plants
- Shipping and shipbuilding
- Firefighting and rescue
- Laboratories and universities
- Volcanic and hot spring sites
- Aerospace
- Food industry
- Miscellaneous: Medical and nursing care / Paper industry / Printing and paints / AC and refrigeration equipment / Energy / FCV and hydrogen stations / Environment and risk assessment

Detection target gases

The detection target gases will vary depending on the particular model (sensors installed).

- Combustible gas (SD-1, SD-1GH, SD-1RI)
- Toxic gas (SD-1GH)
- Hydrogen sulfide (SD-1EC)
- Carbon monoxide (SD-1EC)
- Oxygen (SD-10X)

Explosion-proof

- Explosion-proof
- Non-explosion-proof

Features

- Explosion-proof class Ex db IIC T5...T6 Gb certified, allowing use in hydrogen and acetylene atmospheres
- Simple operation by just placing a dedicated control key
- Compatible with a broad range of measurement environments and measurement range requirements
- Supports external output 4 to 20 mA with HART.

Combustible Gas Smart Transmitter/Gas Detector

SD-1RI



Hydrogen Sulfide/Carbon Monoxide Smart Transmitter/Gas Detector

SD-1EC



Combustible Gas/Toxic Gas Smart Transmitter/Gas Detector

SD-1GH



Oxygen Smart Transmitter/Gas Detector

SD-10X



Specifications

Model	SD-1		SD-1RI	SD-1GH	SD-1EC	SD-10X
TYPE	TYPE GP	TYPE NC	—	—	—	—
Sampling method			Combined suction/diffusion			
Detection target gas	Combustible gas		Combustible gas or toxic gas		CO, H ₂ S	O ₂
Detection principle	Catalytic combustion type	New ceramic type	Non-dispersive infrared type	Semiconductor type	Electrochemical type	Galvanic cell type
Detection range	0 – 100 %LEL		Depends on detection target gas.			0 – 5 vol%, 0 – 10 vol%, 0 – 25 vol%, 0 – 50 vol%, 0 – 100 vol%
Alarm setpoints	Depends on detection target gas.					Depends on detection range.
Alarm type	Gas alarm, fault alarm					
Alarm pattern	Gas alarm: ALM lamp lit (red), fault alarm: FAULT lamp lit (yellow), detail display					
Explosion-proof construction	Flame-proof enclosure					
Explosion-proof class	IECEX: Ex db IIC T5 Gb ATEX: II 2 G Ex db IIC T5 Gb		IECEX: Ex db IIC T6 Gb ATEX: II 2 G Ex db IIC T6 Gb	IECEX: Ex db IIC T5 Gb ATEX: II 2 G Ex db IIC T5 Gb	IECEX: Ex db IIC T6 Gb ATEX: II 2 G Ex db IIC T6 Gb	
Protection level	IP65 equivalent					
Certifications	IECEX, ATEX, Brazil Ex, Taiwan Ex, China Ex, Japan Ex, MED, CE marking		IECEX, ATEX, Brazil Ex, Taiwan Ex, Japan Ex, SIL, CE marking	IECEX, ATEX, Brazil Ex, Taiwan Ex, China Ex, Japan Ex, CE marking	IECEX, ATEX, Brazil Ex, Taiwan Ex, China Ex, Japan Ex, SIL, CE marking	IECEX, ATEX, Brazil Ex, Taiwan Ex, China Ex, Japan Ex, MED, SIL, CE marking
Power source	24 V DC ± 10 %					
External dimensions	Approx. 148 mm (W) × 167 mm (H) × 88 mm (D) (excluding projections)			Approx. 148 mm (W) × 203 mm (H) × 88 mm (D) (excluding projections)	Approx. 148 mm (W) × 208 mm (H) × 88 mm (D) (excluding projections)	
Weight	Approx. 2.0 kg			Approx. 2.2 kg	Approx. 2.5 kg	
Operating temperature range	-20 to +53 °C (no sudden fluctuations)			-10 to +40 °C (no sudden fluctuations)		
Operating humidity range	0 to 95 %RH (no condensation)			30 to 80 %RH (no condensation)		0 to 95 %RH (no condensation)

• SD-1 Series models

SD-1 D TYPE GP-AS

Detection method

- Without D: Diffusion type
- With D: Suction type

Suction method

- Without -AS: Pump suction
- With -AS: Aspirator suction

Detection principle

- TYPE GP: Catalytic combustion type
- TYPE NC: New ceramic type
- RI: Non-dispersive infrared type
- GH: Semiconductor type
- EC: Electrochemical type
- OX: Galvanic cell type

• Simple operation by just placing a control key

The product can be operated using a control key (magnet) without the need to open or close the unit. This ensures safe operation even in explosion-proof areas.



• Connection examples

3-core cables are used for the power supply (24 V DC) and gas concentration signal (4 to 20 mA DC) connection cables. 5-core cables are used for contact output.

■ Connection example with an alarm monitoring system ■ Connection example with an indicator/alarm unit system

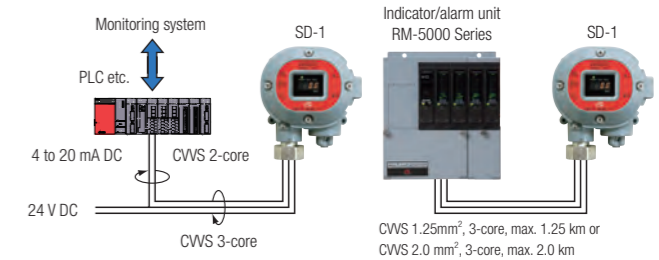

Usable even in hazardous hydrogen and acetylene atmospheres

Oxygen Detector Head

GD-10X



Main areas of use

- Electronics
- Oil refining and petrochemicals
- Construction sites
- Steel plants
- Shipping and shipbuilding
- Firefighting and rescue
- Laboratories and universities
- Volcanic and hot spring sites
- Aerospace
- Food industry
- Miscellaneous: Medical and nursing care / Paper industry / Printing and paints / AC and refrigeration equipment / Energy / FCV and hydrogen stations / Environment and risk assessment

Detection target gases

- Oxygen

Explosion-proof

- Explosion-proof
- Non-explosion-proof

Features

- Oxygen concentration monitoring/general disaster prevention systems for civil engineering work in utility tunnels, underground, etc.
- Oxygen concentration monitoring during tank washing/cleaning
- Oxygen concentration monitoring in enclosed spaces
- Oxygen concentration measurement/monitoring in inert gas

Specifications

Model	GD-10X
Sampling method	Combined suction/diffusion
Detection target gas	O ₂
Detection principle	Galvanic cell type
Alarm type	Depends on indicator used in combination.
Explosion-proof construction	Flame-proof enclosure
Explosion-proof class	Ex d IIC T6 X
Protection level	IP65 equivalent
Certification	Japan Ex
Power source	Supplied from each indicator unit
External dimensions	Approx. 148 mm (W) × 208 mm (H) × 88 mm (D) (excluding projections)
Weight	Approx. 2.5 kg
Operating temperature range	-10 to +40 °C (no sudden fluctuations)
Operating humidity range	0 to 95 %RH (no condensation)

Direct insertion type for accurate concentration detection inside ducts

Flame-proof Furnace Gas Monitor

GD-A2400

SD-2500

SD-2600

SD-2700

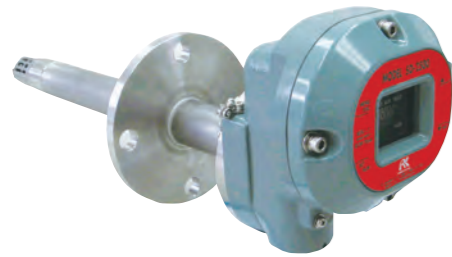

Main areas of use

- Electronics
- Oil refining and petrochemicals
- Construction sites
- Steel plants
- Shipping and shipbuilding
- Firefighting and rescue
- Laboratories and universities
- Volcanic and hot spring sites
- Aerospace
- Food industry
- Miscellaneous: Medical and nursing care / Paper industry / Printing and paints / AC and refrigeration equipment / Energy / FCV and hydrogen stations / Environment and risk assessment

Detection target gases

Combustible gas

Explosion-proof

Explosion-proof Non-explosion-proof *SD-2700 only

Features

- Capable of detecting high boiling point solvents
- Direct furnace interior insertion type for accurate concentration measurements in the middle of exhaust duct interiors
- Integral main unit and display unit construction eliminates the need for a dedicated indicator unit. SD-2500/SD-2600
- Simple operation by just placing a control key
- Ideal for measuring gas concentrations inside drying facilities and exhaust ducts
- Explosion-proof certification temperature range (0 to +160 °C) GD-A2400, SD-2500 (0 to +200 °C) SD-2600
- Can be used at 200 °C or above (operating temperature range 0 to 250 °C). SD-2700

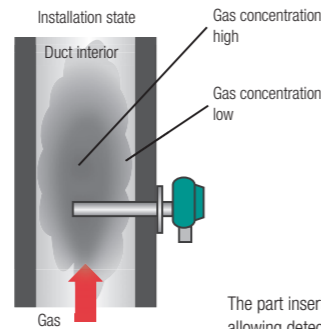

The part inserted in the furnace is 250 mm, allowing detection in the center where gas concentrations are highest.

Specifications

Model	GD-A2400	SD-2500	SD-2600	SD-2700
Sampling method	Duct insertion type, direct furnace interior insertion type			
Detection target gas	Combustible gas			
Detection principle	Catalytic combustion type			
Detection range	0 – 100 %LEL			
Alarm type	Gas alarm, fault alarm			
Explosion-proof construction	Flame-proof enclosure			Non-explosion-proof construction
Explosion-proof class	IECEX: Ex db IIC T3 Gb ATEX: II 2 G Ex db IIC T3 Gb		IECEX: Ex db IIC T2 Gb ATEX: II 2 G Ex db IIC T2 Gb	—
Certifications	IECEX, ATEX, China Ex, UL, Japan Ex, CE marking			
Power source	Supplied from indicator/alarm unit		24 V DC ± 10 %	
External dimensions	Approx. 148 mm (W) × 167 mm (H) × 458 mm (D) (excluding projections) * Including Ø34 mm × 250 mm furnace interior insertion unit			
Weight	Approx. 4.6 kg			
Operating temperature range	Furnace interior insertion part: 0 to +160 °C (no sudden fluctuations) Main unit case ambient temperature: 0 to +50 °C (no sudden fluctuations)		Furnace interior insertion part: 0 to +200 °C (no sudden fluctuations) Main unit case ambient temperature: 0 to +50 °C (no sudden fluctuations)	Furnace interior insertion part: 0 to +250 °C (no sudden fluctuations) Main unit case ambient temperature: 0 to +50 °C (no sudden fluctuations)

Standard type explosion-proof gas detector

Combustible Gas/Toxic Gas Detector Head

GD-A80 Series



GD-A80



GD-A80V

Main areas of use

- Electronics
- Oil refining and petrochemicals
- Construction sites
- Steel plants
- Shipping and shipbuilding
- Firefighting and rescue
- Laboratories and universities
- Volcanic and hot spring sites
- Aerospace
- Food industry
- Miscellaneous: Medical and nursing care / Paper industry / Printing and paints / AC and refrigeration equipment / Energy / FCV and hydrogen stations / Environment and risk assessment

Detection target gases

Combustible gas Toxic gas

Explosion-proof

Explosion-proof Non-explosion-proof

Features

- Capable of detecting combustible gases and toxic gases within various detection ranges
 - Explosion-proof class Ex db IIC T4 Gb allows use even in hydrogen and acetylene atmospheres.
 - Support for suction type and aspirator suction type (* Requires a pump unit and power supply separately.)
 - The GD-A80-70 can be used in hot environments up to 70 °C.
- Type list:
 GD-A80 (catalytic combustion type, new ceramic type)
 GD-A80V (semiconductor type)
 GD-A80S (hot-wire semiconductor type)
 GD-A80N (thermal conductivity type)
 GD-A80-70 (catalytic combustion type)

Specifications

Model	GD-A80, GD-A80V, GD-A80-70, etc.
Sampling method	Diffusion type
Detection principle	Refer to the type list.
Alarm type	Depends on indicator used in combination.
Explosion-proof construction	Flame-proof enclosure
Explosion-proof class	IECEX: Ex db IIC T4 Gb ATEX: II 2 G Ex db IIC T4 Gb
Protection level	IP67 equivalent
Certifications	IECEX, ATEX, China Ex, Japan Ex, CE marking
Power source	Supplied from indicator/alarm unit
External dimensions	Approx. 78 mm (W) × 163 mm (H) × 105 mm (D) (excluding projections)
Weight	Approx. 1.0 kg
Operating temperature range	-20 to +53 °C (no sudden fluctuations) [GD-A80-70: -40 to +70 °C (no sudden fluctuations)]
Operating humidity range	0 to 95 %RH (no condensation)

Indicator/alarm unit - detector connection example



RM-6000 Series



RM-5000 Series
Multi-case



RM-5000 Series
Single case

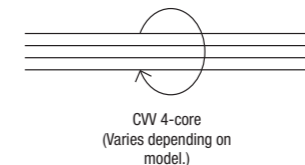

CW 4-core
(Varies depending on model.)



GD-A80 Series

Can be connected to the corresponding detector for the target gas.

Equipped with high-capacity suction pump

Flame-proof Suction Type Gas Detector (Direct Transmission Type)

GD-D58 Series



GD-D58 · AC

Flame-proof Suction Type Gas Detector (Signal Converter Type)

SD-D58 Series



SD-D58 · AC

Flame-proof Pump Unit

RP-D58

Features

- Can be used as explosion-proof products even in hydrogen atmospheres.
- Equipped with automatic flow abnormality detection function
- Integrated assemblies of replacement parts for improved maintainability
- Dust-proof/waterproof enclosure (IP67 equivalent)

Main areas of use

Electronics	Oil refining and petrochemicals	Construction sites	Steel plants	Shipping and shipbuilding
Firefighting and rescue	Laboratories and universities	Volcanic and hot spring sites	Aerospace	Food industry
Miscellaneous	Medical and nursing care / Paper industry / Printing and paints / AC and refrigeration equipment Energy / FCV and hydrogen stations / Environment and risk assessment			

Detection target gases

The detection target gases will vary depending on the particular model (sensors installed).

Combustible gas	Toxic gas
-----------------	-----------

Explosion-proof

Explosion-proof	Non-explosion-proof
-----------------	---------------------

Features

- Can be used as explosion-proof products even in hydrogen atmospheres.
- Equipped with automatic flow abnormality detection function
- Integrated assemblies of replacement parts for improved maintainability
- Dust-proof/waterproof enclosure (IP67 equivalent)
- Can be maintained by one person. **SD-D58 Series only**

Specifications

Model	GD-D58, GD-D58 · GH, etc.	SD-D58, SD-D58 · GH, etc.
Sampling method	Suction type	
Detection principle	Catalytic combustion type, new ceramic type, semiconductor type, hot-wire semiconductor type, thermal conductivity type	
Detection range	Depends on detection target gas.	
Alarm setpoints	Depends on detection target gas.	
Alarm type	Fault alarm	Gas alarm, fault alarm
Alarm pattern	Fault alarm: FAULT lamp lit (yellow)/detail display	Gas alarm: ALM lamp lit (red) Fault alarm: FAULT lamp lit (yellow)/detail display
Explosion-proof construction	Flame-proof enclosure	
Explosion-proof class	ATEX: II 2 G Ex db h IIB + H2 T4 Gb	
Protection level	IP67 equivalent	
Certifications	ATEX, Taiwan Ex, China Ex, Japan Ex, CE marking	
Power source	100 to 110 V AC ± 10 %, 50/60 Hz or 24 V DC ± 10 %	100 V AC or 24 V DC ± 10 %
External dimensions	Approx. 197 mm (W) × 292 mm (H) × 140 mm (D) (excluding projections)	Approx. 197 mm (W) × 292 mm (H) × 140 mm (D) (excluding projections)
Weight	Approx. 5.8 kg	
Operating temperature range	AC model: -20 to +50 °C (no sudden fluctuations) DC model: -20 to +53 °C (no sudden fluctuations)	
Operating humidity range	0 to 95 %RH (no condensation)	

* For information on other communication methods, please contact RIKEN KEIKI.

Specifications

Model	RP-D58
Sampling method	Suction type
Alarm type	Fault alarm
Alarm pattern	Fault alarm: FAULT lamp lit (yellow)/detail display
Explosion-proof construction	Flame-proof enclosure
Explosion-proof class	ATEX: II 2 G Ex db h IIB + H2 T4 Gb
Protection level	IP67 equivalent
Certifications	ATEX, Taiwan Ex, Japan Ex, CE marking
Power source	100 V to 110 V AC, 50/60 Hz 24 V DC ± 10 %
External dimensions	Approx. 197 mm (W) × 292 mm (H) × 140 mm (D) (excluding projections)
Weight	Approx. 5.8 kg
Operating temperature range	AC model: -20 to +50 °C (no sudden fluctuations) DC model: -20 to +53 °C (no sudden fluctuations)
Operating humidity range	0 to 95 %RH (no condensation)

Intrinsically safe explosion-proof construction 2-wire toxic gas detector

Toxic Gas Detector Head

GD-88 Series GD-K88Ai GD-K88Di



GD-K88Ai

Refer to Page 37. ◀ For oxygen detection



GD-K88Di

Refer to Page 37. ◀ For oxygen detection

Main areas of use

Electronics	Oil refining and petrochemicals	Construction sites	Steel plants	Shipping and shipbuilding
Firefighting and rescue	Laboratories and universities	Volcanic and hot spring sites	Aerospace	Food industry
Miscellaneous	Medical and nursing care / Paper industry / Printing and paints / AC and refrigeration equipment Energy / FCV and hydrogen stations / Environment and risk assessment			

Detection target gases

The detection target gases will vary depending on the sensors installed.

Toxic gas

Explosion-proof

Explosion-proof	Non-explosion-proof
-----------------	---------------------

Features

- Two-wire gas detector: Allows direct transmission to control system.
- Corrosive gas resistant enclosure: SUS enclosure available upon customer request
- Intrinsically safe explosion-proof construction combined with safety barrier
- Built-in aspirator (optional) **GD-K88Di**
- Supports output with HART.

Specifications

Model	GD-K88Ai
Sampling method	Diffusion type
Detection principle	Electrochemical type
Detection range	Depends on detection target gas.
Alarm setpoints	Depends on detection target gas.
Alarm type	Gas alarm, fault alarm
Alarm pattern	Alarm message (AL1/AL2) display
Explosion-proof construction	Intrinsically safe explosion-proof construction
Explosion-proof class	Ex ia IIC T4 Ga (when using safety barrier)
Certification	Japan Ex
Power source	24 V DC ± 10 %
External dimensions	Approx. 100 mm (W) × 241 mm (H) × 48 mm (D)
Weight	Approx. 1.0 kg
Operating temperature range	0 to +40 °C (no sudden fluctuations; may vary depending on the sensors installed.)
Operating humidity range	30 to 70 %RH (no condensation; may vary depending on the sensors installed.)

Specifications

Model	GD-K88Di
Sampling method	Suction type
Detection principle	Electrochemical type
Detection range	Depends on detection target gas.
Alarm setpoints	Depends on detection target gas.
Alarm type	Gas alarm, fault alarm
Alarm pattern	Alarm message (AL1/AL2) display
Explosion-proof construction	Intrinsically safe explosion-proof construction
Explosion-proof class	Ex ia IIC T4 Ga (when using safety barrier)
Certification	Japan Ex
Power source	24 V DC ± 10 %
External dimensions	Approx. 220 mm (W) × 265 mm (H) × 90 mm (D)
Weight	Approx. 2.6 kg
Operating temperature range	0 to +40 °C (no sudden fluctuations; may vary depending on the sensors installed.)
Operating humidity range	30 to 70 %RH (no condensation; may vary depending on the sensors installed.)

Intrinsically safe explosion-proof construction 2-wire oxygen detector

Oxygen Detector Head

GD-88 Series

GD-F88Ai

GD-F88Di



GD-F88Ai

Refer to Page 36. ◀ For toxic gas detection



GD-F88Di

Refer to Page 36. ◀ For toxic gas detection

Main areas of use

Electronics	Oil refining and petrochemicals	Construction sites	Steel plants	Shipping and shipbuilding
Firefighting and rescue	Laboratories and universities	Volcanic and hot spring sites	Aerospace	Food industry
Miscellaneous	Medical and nursing care / Paper industry / Printing and paints / AC and refrigeration equipment / Energy / FCV and hydrogen stations / Environment and risk assessment			

Detection target gases

Oxygen

Explosion-proof

Explosion-proof / Non-explosion-proof

Features

- Two-wire gas detector: Allows direct transmission to control system.
- Equipped with pressure correction sensor: Virtually unaffected by pressure fluctuations
- Corrosive gas resistant enclosure: SUS enclosure available at customer request.
- Intrinsically safe explosion-proof construction combined with safety barrier
- Built-in aspirator (optional) [GD-F88Di](#)
- Supports output with HART.

Specifications

Model	GD-F88Ai
Sampling method	Diffusion type
Detection target gas	O ₂
Detection principle	Galvanic cell type
Detection range	0 – 5 vol%, 0 – 10 vol%, 0 – 25 vol%
Alarm setpoints	Depends on detection range.
Alarm type	Gas alarm, fault alarm
Alarm pattern	Alarm message (AL1/AL2) display
Explosion-proof construction	Intrinsically safe explosion-proof construction
Explosion-proof class	Ex ia IIC T4 Ga (when using safety barrier)
Certification	Japan Ex
Power source	24 V DC ± 10 %
External dimensions	Approx. 100 mm (W) × 241 mm (H) × 48 mm (D)
Weight	Approx. 1 kg
Operating temperature range	-10 to +40 °C (no sudden fluctuations)
Operating humidity range	0 to 95 %RH (no condensation)

Specifications

Model	GD-F88Di
Sampling method	Suction type
Detection target gas	O ₂
Detection principle	Galvanic cell type
Detection range	0 – 5 vol%, 0 – 10 vol%, 0 – 25 vol%
Alarm setpoints	Depends on detection range.
Alarm type	Gas alarm, fault alarm
Alarm pattern	Alarm message (AL1/AL2) display
Explosion-proof construction	Intrinsically safe explosion-proof construction
Explosion-proof class	Ex ia IIC T4 Ga (when using safety barrier)
Certification	Japan Ex
Power source	24 V DC ± 10 %
External dimensions	Approx. 220 mm (W) × 265 mm (H) × 90 mm (D)
Weight	Approx. 2.5 kg
Operating temperature range	-10 to +40 °C (no sudden fluctuations)
Operating humidity range	0 to 95 %RH (no condensation)

Oxygen Detector Head

GD-F3A-A

GD-F3A-SC-A

GD-F4A-A

GD-F4A-SC-A



Detection method by model

Model	Sampling method	Detector signal
GD-F3A-A	Diffusion type	Direct sensor output signal
GD-F3A-SC-A		Current signal (4 to 20 mA DC)
GD-F4A-A	Suction type	Direct sensor output signal
GD-F4A-SC-A		Current signal (4 to 20 mA DC)

Main areas of use

Electronics	Oil refining and petrochemicals	Construction sites	Steel plants	Shipping and shipbuilding
Firefighting and rescue	Laboratories and universities	Volcanic and hot spring sites	Aerospace	Food industry
Miscellaneous	Medical and nursing care / Paper industry / Printing and paints / AC and refrigeration equipment / Energy / FCV and hydrogen stations / Environment and risk assessment			

Detection target gases

Oxygen

Explosion-proof

Explosion-proof / Non-explosion-proof

Features

- Compact lightweight design allows easy installation anywhere. [GD-F3A-A/GD-F3A-SC-A](#)
- Splash-proof construction allows installation even outdoors.
- Diffusion-type GD-F3A-A base with addition of suction flow paths [GD-F4A-A/GD-F4A-SC-A](#)
- The GD-F3A-SC-A incorporates a 4 to 20 mA transmission signal converter for easy installation and long-distance transmission (up to 2.0 km).
- The GD-F4A-SC-A uses 4 to 20 mA transmission for long-distance transmission (up to 2.0 km).

Specifications

Model	GD-F3A-A	GD-F3A-SC-A
Sampling method	Diffusion type	
Detection target gas	O ₂	
Detection principle	Galvanic cell type	
Detection range	0 – 25 vol%	
Explosion-proof construction	Intrinsically safe explosion-proof construction	
Explosion-proof class	Ex ia IIC T4 X (when using Zener barrier)	
Certifications	Japan Ex, CE marking (GD-F3A-A)	
Power source	24 V DC (Supplied from indicator/alarm unit)	
Detector signal	Direct sensor output signal	Current signal (4 to 20 mA DC)
External dimensions	Approx. 140 mm (W) × 175 mm (H) × 86 mm (D)	Approx. 140 mm (W) × 175 mm (H) × 95 mm (D)
Weight	Approx. 1.4 kg	Approx. 1.6 kg
Operating temperature range	-10 to +40 °C (no sudden fluctuations)	
Operating humidity range	0 to 95 %RH (no condensation)	

Specifications

Model	GD-F4A-A	GD-F4A-SC-A
Sampling method	Suction type	
Detection target gas	O ₂	
Detection principle	Galvanic cell type	
Explosion-proof construction	Intrinsically safe explosion-proof construction	
Explosion-proof class	Ex ia IIC T4 X (when using Zener barrier)	
Certifications	Japan Ex, CE marking (GD-F4A-A)	
Power source	24 V DC (Supplied from indicator/alarm unit)	
Detector signal	Direct sensor output signal	Current signal (4 to 20 mA DC)
External dimensions	Approx. 140 mm (W) × 175 mm (H) × 86 mm (D)	Approx. 140 mm (W) × 175 mm (H) × 95 mm (D)
Weight	Approx. 1.5 kg	Approx. 1.7 kg
Operating temperature range	-10 to +40 °C (no sudden fluctuations)	
Operating humidity range	0 to 95 %RH (no condensation)	

High-precision calorimeter based on proprietary calculation method

Explosion-proof Calorimeter

OHC-800



OHC-800 and RS-400 Series sampling unit

- Large character LCD for easy viewing

Uses RIKEN KEIKI's proprietary optsonic calculation method for reliable high-precision calorimetric measurements that eliminate the effects of gases without calorific value (e.g. N₂, O₂, CO₂) within fuel gases.

- Display switchable between calorific value (MJ/m³), specific gravity, and Wobbe index

Allows selection of display units using just the display keys to eliminate the need to calculate values.

- Allows continuous measurement of calorific value (MJ/m³), specific gravity, and Wobbe index.

Allows continuous measurement of calorific value (MJ/m³), specific gravity, and Wobbe index for on-site calorific value monitoring.

- Explosion-proof in hydrogen environments

Rugged flame-proof enclosure (explosion-proof class: Ex db IIB + H2 T4 Gb) allows use even in hydrogen atmospheres.

Main areas of use

Electronics	Oil refining and petrochemicals	Construction sites	Steel plants	Shipping and shipbuilding
Firefighting and rescue	Laboratories and universities	Volcanic and hot spring sites	Aerospace	Food industry
Miscellaneous	Medical and nursing care / Paper industry / Printing and paints / AC and refrigeration equipment / Energy / FCV and hydrogen stations / Environment and risk assessment			

Measurement target gases

Calorific value

Explosion-proof

Explosion-proof Non-explosion-proof

Features

- Incorporates RIKEN KEIKI's unique Riken optsonic calculation method (Japanese Patent No. 5184983). Resistant to influence from incombustible gases for high-precision measurements
- Fast response at 90 % response within 5 seconds
- High repetition accuracy within ±0.02 MJ/m³
- Hydrogen explosion-proof construction (Ex db IIB+H2 T4 Gb) required for calorimeters allows installation in dangerous areas.
- Excellent temperature characteristics, with temperature change of 0.10 MJ/m³ or less per day
- Calorific value/specific gravity/Wobbe index switchable with key operation, eliminating troublesome calculations

Specifications

Model	OHC-800
Sampling method	Suction type
Measurement target gasses	Gases consisting of paraffin-based hydrocarbon gases primarily containing methane, typified by natural gas ^{*1}
Measurement range	Calorific measurement range: 25.00 to 50.00 MJ/m ³ (Gross, 0 °C, 101.325 kPa conversion value) Density measurement range: 0.500 to 1.500 (Specific gravity conversion)
Explosion-proof construction	Flame-proof enclosure
Explosion-proof class	IECEX: Ex db IIB + H2 T4 Gb ATEX: II 2 G Ex db + H2 T4 Gb
Protection level	IP66/67 equivalent
Certifications	IECEX, ATEX, China Ex, FM, Japan Ex, CE marking
Power source	100 to 240 V AC ± 10 %, 50/60 Hz (max. 18 VA) or 24 V DC ± 10 % (max. 5 W) Can be switched between AC/DC.
External dimensions	Approx. 286 mm (W) × 453 mm (H) × 150 mm (D)
Weight	Approx. 23 kg
Operating temperature range	-20 to +57 °C (no sudden fluctuations)
Operating humidity range	0 to 95 %RH (no condensation)

^{*1}: This assumes that the total amount of gases such as N₂, O₂, CO₂, and CO included in the measurement target gas does not exceed 20 %.

* For information on other measurement ranges, contact RIKEN KEIKI.

Sampling unit models

Can be used in combination with the dedicated RS-400 Series sampling unit for the OHC-800 to handle a wide range of installation parameters, including installation location and sampling pressure. (Please select the model to suit the intended operating environment.)



RS-400-

Storage box
0: No storage box
1: Outdoor (SUS) box with shade plate
2: Indoor (SPCC) box with window

Measurement target gas pressure reduction valve
Select a model with a pressure reduction valve if the sampling point is pressurized.
0: No pressure reduction valve
1: With pressure reduction valve

Measurement target bypass flow rate
"0: No bypass" is automatically selected for models with no pressure reduction valve.
0: No bypass
1: 0.5 to 5 L/min
2: 1 to 10 L/min
3: 2 to 20 L/min

Pressure gauge scale units
Select "1: MPa" for use within Japan in accordance with the Measurement Act.
1: MPa
2: MPa/PSI dual scale pressure gauge

Uses reliable optical interferometric sensors.

Optical Interferometric Gas Monitor

FI-900



Features

- Uses reliable optical interferometric sensors.
- Sensors characterized by long-term stability and no sensitivity degradation eliminate the need for replacement over the actual service life of 10 years.
- Measurements are based on the characteristic refractive index of the target gas to allow measurement of virtually any gas type.
- Capable of measuring even corrosive gases like NH₃ and VCM
- Flame-proof enclosure allows use even in H₂ atmospheres.
- Incorporates improved self-diagnostic functions and Modbus communication allowing monitoring of status as well as gas concentrations.
- Ideal for VOC explosion prevention/concentration control and hydrogen purity measurement

Main areas of use

Electronics	Oil refining and petrochemicals	Construction sites	Steel plants	Shipping and shipbuilding
Firefighting and rescue	Laboratories and universities	Volcanic and hot spring sites	Aerospace	Food industry
Miscellaneous	Medical and nursing care / Paper industry / Printing and paints / AC and refrigeration equipment / Energy / FCV and hydrogen stations / Environment and risk assessment			

Measurement target gases

Depends on sensor installed

Explosion-proof

Explosion-proof Non-explosion-proof

Specifications

Model	FI-900
Sampling method	Suction type
Measuring principle	Optical interferometric type
Measurement range	Depends on gas specification.
Alarm setpoints	Depends on gas specification.
Explosion-proof construction	Flame-proof enclosure
Explosion-proof class	IECEX: Ex db IIB + H2 T4 Gb ATEX: II 2 G Ex db IIB + H2 T4 Gb
Protection level	IP66/67 equivalent
Certifications	IECEX, ATEX, Japan Ex, CE marking
Power source	100 to 240 V AC ± 10 %, 50/60 Hz, 24 V DC ± 10 % * IECEX/ATEX models are DC only.
External dimensions	Approx. 286 mm (W) × 453 mm (H) × 150 mm (D) (excluding projections)
Weight	Approx. 23 kg
Operating temperature range	IECEX/ATEX: -20 to +60 °C (no sudden fluctuations) Japan Ex: -20 to +57 °C (no sudden fluctuations)
Operating humidity range	0 to 95 %RH (no condensation of water/gas inside product)
Operating pressure range	Atmospheric pressure (with no surging)

Ideal for explosion prevention control inside drying ovens

Optical Interferometric Gas Monitor

FI-915



Features

- Rapid response, long-term consistency, and easy operation without need for warm-up
- No sensitivity deterioration due to silicon
- Features temperature and atmospheric pressure correction functions.
- Supports up to eight different gas ranges.
- * Can be specified at time of purchase.
- Increased size LCD screen for improved visibility
- Allows easy pump unit replacement.
- Fully compatible with previous FI-815A model

Main areas of use

Electronics	Oil refining and petrochemicals	Construction sites	Steel plants	Shipping and shipbuilding
Firefighting and rescue	Laboratories and universities	Volcanic and hot spring sites	Aerospace	Food industry
Miscellaneous	Medical and nursing care / Paper industry / Printing and paints / AC and refrigeration equipment / Energy / FCV and hydrogen stations / Environment and risk assessment			

Measurement target gases

Depends on sensor installed

Explosion-proof

Explosion-proof Non-explosion-proof

Specifications

Model	FI-915
Sampling method	Suction type
Measuring principle	Optical interferometric type
Measurement range	0 – 100 %LEL
Alarm type	Gas alarm, fault alarm
Alarm pattern	Lamp lit
Power source	100 to 240 V AC ± 10 %, 50/60 Hz
External dimensions	Approx. 370 mm (W) × 150 mm (H) × 269 mm (D) (excluding projections)
Weight	Approx. 6 kg
Operating temperature range	-10 to +50 °C (no sudden fluctuations)
Operating humidity range	0 to 95 %RH (no condensation of water/gas inside product)

Detection tape gas monitor ideal for cleanroom environmental monitoring

Highly Sensitive Toxic Gas Monitor

FP-300 FP-301



Detection target gas list

Detection target gas	Detection range
PH ₃	0 – 500 ppb*
	0 – 900 ppb
AsH ₃	0 – 150 ppb
	0 – 100 ppb
H ₂ S	0 – 1,000 ppb
	0 – 10 ppm
SiH ₄	0 – 8 ppm*
	0 – 15 ppm
B ₂ H ₆	0 – 300 ppb
GeH ₄	0 – 2 ppm
	0 – 6 ppm
Cl ₂	0 – 0.8 ppm*
	0 – 1.5 ppm
Si ₂ H ₆	0 – 10 ppm
TBA	0 – 150 ppb
HCl	0.25 – 1 ppm
	1.5 – 8 ppm
HF	0 – 9 ppm
NH ₃	0.5 – 4 ppm

* For detoxification systems

Main areas of use

Electronics	Oil refining and petrochemicals	Construction sites	Steel plants	Shipping and shipbuilding
Firefighting and rescue	Laboratories and universities	Volcanic and hot spring sites	Aerospace	Food industry
Miscellaneous	Medical and nursing care / Paper industry / Printing and paints / AC and refrigeration equipment / Energy / FCV and hydrogen stations / Environment and risk assessment			

Detection target gases

Depends on detection target gas

Explosion-proof

Explosion-proof Non-explosion-proof

Features

- Excellent selectivity with minimal interference from other gases
- Rapid detection of minute environmental changes (Detectable at ppb level)
- Cassette insertion method for easy tape replacement (Using microcassette)
- Arsine detection range of 0 – 15 ppb supports new ACGIH acceptable concentration (5 ppb) **FP-301**

Specifications

Model	FP-300
Sampling method	Suction type
Detection target gas	Toxic gas
Detection principle	Detection tape method
Detection range	Refer to the detection target gas list.
Alarm setpoints	Depends on detection target gas.
Alarm type	Gas alarm, fault alarm
Alarm pattern	Lamp lit, buzzer
Detection tape usage time	1 month (with no alarms), with remaining tape amount indication, tape end indication/warning
Certification	CE marking (AC model only)
Power source	Tabletop type: 100 to 240 V AC ± 10 %, 50/60 Hz Panel-mounted type: 24 V DC ± 10 %
External dimensions	Tabletop type: Approx. 164 mm (W) × 198 mm (H) × 263 mm (D) Panel-mounted type: Approx. 164 mm (W) × 164 mm (H) × 263 mm (D) (excluding projections)
Weight	Tabletop type: Approx. 6.5 kg Panel-mounted type: Approx. 5.5 kg
Operating temperature range	+5 to 35 °C (no sudden fluctuations)
Operating humidity range	30 to 80 %RH (no condensation) * May vary depending on tape used.

Specifications

Model	FP-301
Sampling method	Suction type
Detection target gas	AsH ₃ (Arsine) H ₂ Se (Hydrogen selenide)
Detection principle	Detection tape method
Detection range	AsH ₃ : 0 – 15 ppb H ₂ Se: 0 – 200 ppb
Alarm setpoints	AsH ₃ : 5 ppb (WARNING)/10 ppb (ALARM) H ₂ Se: 50 ppb (WARNING)/100 ppb (ALARM)
Alarm type	Gas alarm, fault alarm
Alarm pattern	Lamp lit, buzzer sounding
Detection tape usage time	1 month (with no alarms), with remaining tape amount indication, tape end indication/warning
Certification	CE marking (AC model only)
Power source	Tabletop type: 100 to 240 V AC ± 10 %, 50/60 Hz Panel-mounted type: 24 V DC ± 10 %
External dimensions	Tabletop type: Approx. 164 mm (W) × 198 mm (H) × 263 mm (D) Panel-mounted type: Approx. 164 mm (W) × 164 mm (H) × 263 mm (D) (excluding projections)
Weight	Tabletop type: Approx. 6.5 kg Panel-mounted type: Approx. 5.5 kg
Operating temperature range	+5 to 35 °C (no sudden fluctuations)
Operating humidity range	30 to 80 %RH (no condensation) * May vary depending on tape used.

Exceptionally high detection sensitivity; ideal for low-concentration monitoring

C₅F₈/C₄F₆

Highly Sensitive Toxic Gas Monitor

FP-300AGZS



Main areas of use

Electronics	Oil refining and petrochemicals	Construction sites	Steel plants	Shipping and shipbuilding
Firefighting and rescue	Laboratories and universities	Volcanic and hot spring sites	Aerospace	Food industry
Miscellaneous	Medical and nursing care / Paper industry / Printing and paints / AC and refrigeration equipment / Energy / FCV and hydrogen stations / Environment and risk assessment			

Detection target gases

Depends on detection target gas

Explosion-proof

Explosion-proof Non-explosion-proof

Features

- Excellent selectivity with minimal interference from other gases
- Cassette insertion method for easy tape replacement

Specifications

Model	FP-300AGZS
Sampling method	Suction type
Detection target gas	C ₅ F ₈ (Octafluorocyclopentene) C ₄ F ₆ (Perfluorobutadiene)
Detection principle	Detection tape method
Detection range	0 – 5.0 ppm
Alarm setpoints	2.0 ppm (WARNING), 4.0 ppm (ALARM)
Alarm type	Gas alarm, fault alarm
Alarm pattern	Lamp lit, buzzer sounding
Detection tape usage time	2 months (with no alarms), with remaining tape amount indication, tape end indication/warning
Power source	100 to 240 V AC, 50/60 Hz (power consumption: 150 VA or less)
External dimensions	Approx. 250 mm (W) × 198 mm (H) × 300 mm (D) (excluding projections)
Weight	Approx. 9.5 kg
Operating temperature range	+5 to 35 °C (no sudden fluctuations)
Operating humidity range	30 to 90 %RH (no condensation)

Excellent selectivity free of interference from other gases

AsH₃

Highly Sensitive Toxic Gas Monitor

FP-270As



Main areas of use

Electronics	Oil refining and petrochemicals	Construction sites	Steel plants	Shipping and shipbuilding
Firefighting and rescue	Laboratories and universities	Volcanic and hot spring sites	Aerospace	Food industry
Miscellaneous	Medical and nursing care / Paper industry / Printing and paints / AC and refrigeration equipment / Energy / FCV and hydrogen stations / Environment and risk assessment			

Detection target gases

AsH₃

Explosion-proof

Explosion-proof Non-explosion-proof

Specifications

Model	FP-270As
Detection target gas	AsH ₃ (Arsine)
Detection principle	Detection tape method
Detection range	0 – 15 ppm
Alarm setpoints	5 ppb (WARNING), 10 ppb (ALARM)
Alarm pattern	Lamp lit, buzzer sounding
Detection tape usage time	1 month (with no alarms), with remaining tape amount indication, tape end indication/warning
External output	4 to 20 mA DC (load resistance 300 Ω or less), 0 to 1 V DC
Power source	100 V AC ± 10 %, 50/60 Hz (power consumption: max. 40 VA)
External dimensions/weight	Approx. 300 mm (W) × 200 mm (H) × 370 mm (D) / Approx. 13.4 kg
Operating temperature range	+5 to 35 °C (no sudden fluctuations)
Operating humidity range	30 to 90 %RH (no condensation)

Measures infrared long-wavelength region to detect fluorine compounds and solvents.

Infrared Type Fluorocarbon/ IPA Gas Monitor

RI-257



Features

- Space-saving design allows easy mounting.
- Digital display
- Minimal effects from interference gases
- Outstanding long-term consistency with virtually no sensitivity degradation
- Infrared type eliminates virtually all consumable parts.

Main areas of use

- Electronics
 Oil refining and petrochemicals
 Construction sites
 Steel plants
 Shipping and shipbuilding
 Firefighting and rescue
 Laboratories and universities
 Volcanic and hot spring sites
 Aerospace
 Food industry
 Miscellaneous
 Medical and nursing care / Paper industry / Printing and paints / AC and refrigeration equipment
 Energy / FCV and hydrogen stations / Environment and risk assessment

Detection target gases

The detection target gases will vary depending on the particular sensor types installed.

- Fluorocarbon gas
 PFC gas
 Solvent gases

Explosion-proof

- Explosion-proof
 Non-explosion-proof

Specifications

Model	RI-257
Sampling method	Suction type
Detection principle	Non-dispersive infrared type
Detection range	Depends on detection target gas.
Alarm pattern	Lamp lit
Power source	100 V AC \pm 10 % or 24 V DC \pm 10 %
External dimensions	Approx. 180 mm (W) \times 355 mm (H) \times 97 mm (D) (excluding projections)
Weight	Approx. 3.8 kg
Operating temperature range	0 to +45 °C (no sudden fluctuations)
Operating humidity range	30 to 90 %RH (no condensation)

Ideal for automatic ventilation, energy-saving air-conditioning control, and air quality management

Infrared Type CO₂ Monitor

RI-215D



Main areas of use

- Electronics
 Oil refining and petrochemicals
 Construction sites
 Steel plants
 Shipping and shipbuilding
 Firefighting and rescue
 Laboratories and universities
 Volcanic and hot spring sites
 Aerospace
 Food industry
 Miscellaneous
 Medical and nursing care / Paper industry / Printing and paints / AC and refrigeration equipment
 Energy / FCV and hydrogen stations / Environment and risk assessment

Detection target gases

- Carbon dioxide

Explosion-proof

- Explosion-proof
 Non-explosion-proof

Features

- Space-saving design allows easy mounting.
- External output (4 to 20 mA) with control contact output
- For automatic ventilation and energy-saving air-conditioning control
- Internal pump allows suction measurement from sampling points.

Specifications

Model	RI-215D
Sampling method	Suction type
Detection target gas	CO ₂
Detection principle	Non-dispersive infrared type
Detection range	ppm model: 0 – 2,000 ppm, 0 – 5,000 ppm, 0 – 9,990 ppm Vol% model: 0 – 2 vol%, 0 – 5 vol%
Power source	100 V AC \pm 10 %, 50/60 Hz; 110 V AC \pm 10 %, 50/60 Hz; 220 V AC \pm 10 %, 50/60 Hz
External dimensions	Approx. 220 mm (W) \times 265 mm (H) \times 76 mm (D) (excluding projections)
Weight	Approx. 3.6 kg
Operating temperature range	0 to +40 °C (no sudden fluctuations)
Operating humidity range	10 to 90 %RH (no condensation)

For easy measurement of gases such as CO, CO₂, and hydrocarbon

Transportable Infrared Gas Monitor

RI-557



Portable model

Features

- Compact and lightweight for portability
- With external output
- Automatic suction using built-in pump
- Automatically switching double range display
- Features low flow rate alarm.
- Lineup of different measurement ranges
- Infrared type eliminates virtually all consumable parts.

Main areas of use

- Electronics
 Oil refining and petrochemicals
 Construction sites
 Steel plants
 Shipping and shipbuilding
 Firefighting and rescue
 Laboratories and universities
 Volcanic and hot spring sites
 Aerospace
 Food industry
 Miscellaneous
 Medical and nursing care / Paper industry / Printing and paints / AC and refrigeration equipment
 Energy / FCV and hydrogen stations / Environment and risk assessment

Detection target gases

The detection target gases will vary depending on the particular sensor types installed.

- Carbon monoxide
 Carbon dioxide
 Hydrocarbons

Explosion-proof

- Explosion-proof
 Non-explosion-proof

Specifications

Model	RI-557
Sampling method	Suction type
Detection target gas	CO ₂ , CH ₄ , CO, I-C ₄ H ₁₀ , C ₂ H ₆ , etc.
Detection principle	Non-dispersive infrared type
Detection range	Depends on detection target gas.
Alarm type	Gas alarm, fault alarm
Alarm pattern	Lamp lit, detail display
Power source	100 to 220 V AC \pm 10 %, 50/60 Hz
External dimensions	Approx. 220 mm (W) \times 200 mm (H) \times 320 mm (D) (excluding projections)
Weight	Approx. 5.7 kg
Operating temperature range	0 to +40 °C (no sudden fluctuations)
Operating humidity range	0 to 90 %RH (no condensation)

Compact, lightweight design with 3-color LCD screen for superior visibility

600 Series

Indoor Oxygen Monitor

OX-600

Indoor Carbon Monoxide Monitor

EC-600

Indoor CO₂ Monitor

RI-600



Main areas of use

- Electronics
- Oil refining and petrochemicals
- Construction sites
- Steel plants
- Shipping and shipbuilding
- Firefighting and rescue
- Laboratories and universities
- Volcanic and hot spring sites
- Aerospace
- Food industry
- Miscellaneous
- Medical and nursing care / Paper industry / Printing and paints / AC and refrigeration equipment
- Energy / FCV and hydrogen stations / Environment and risk assessment

Detection target gases

The detection target gases will vary depending on the particular model (specific sensor types installed).

- Oxygen
- Carbon monoxide
- Carbon dioxide

Explosion-proof

- Explosion-proof
- Non-explosion-proof

Features

- Built-in pressure correction sensor eliminates reading fluctuations due to pressure changes. **OX-600**
- High visibility LCD screen illuminates in green, orange, or red, depending on the operational state.
- Selectable from three power supply types to suit the usage environment: AC power, DC power, or dry battery type **OX-600/EC-600**
- Allows remote measurement at distances up to 20 m with optional remote sensor.
- Complies with JIS T 8201:2010 (Oxygen deficiency indicator) requirements. **OX-600**



Remote sensor [Optional]



Normal (Green)



Caution alarm (Orange)



Danger alarm (Red)

Specifications

Model	OX-600	EC-600	RI-600
Sampling method		Diffusion type	
Detection target gas	O ₂	CO	CO ₂
Detection principle	Galvanic cell type	Electrochemical type	Non-dispersive infrared type
Detection range	0 – 25.0 vol% or 0 – 50.0 vol%	0 – 150 ppm	0 – 2,000 ppm/0 – 5,000 ppm/0 – 10,000 ppm/ 0 – 2 vol%/0 – 5 vol%
Alarm setpoints	0 – 25.0 vol% 1st: 19.0 vol% 2nd: 18.0 vol% 0 – 50.0 vol% 1st: 18.0 vol% 2nd: 25.0 vol%	1st: 50 ppm 2nd: 100 ppm (default setting)	ppm 1st/2nd: 1,000 ppm 0 – 2 vol% 1st/2nd: 1.0 vol% 0 – 5 vol% 1st/2nd: 2.5 vol%
Alarm type	Gas alarm, fault alarm		
Alarm pattern	Lamp lit, buzzer sounding, detail display		
Certifications	CE marking (DC model only), JIS	CE marking (DC model only)	
Power source	100 V AC ± 10 % or 24 V DC ± 10 % or Dry batteries (AA alkaline batteries × 2)		100 V AC ± 10 % or 24 V DC ± 10 %
Continuous operating time	Approx. 1 year (25 °C, no alarms, backlight switched off) * Using dry batteries		
External dimensions	Main unit: Approx. 80 mm (W) × 120 mm (H) × 35.5 mm (D), Remote sensor: Approx. 40 mm (W) × 96 mm (H) × 35.5 mm (D)		
Weight	Main unit: AC power type approx. 200 g, DC power type approx. 180 g, dry battery type approx. 230 g Remote sensor: Approx. 55 g (excluding cables), AC adapter: Approx. 82 g (including cables)		Main unit: AC power type approx. 200 g, DC power type approx. 180 g Remote sensor: Approx. 55 g (excluding cables)
Operating temperature range	-10 to +40 °C (no sudden fluctuations)	0 to +40 °C (no sudden fluctuations)	
Operating humidity range	0 to 90 %RH (no condensation)		
Operating pressure range	Atmospheric pressure (80 to 105 kPa)	—	

Can be combined with various different detectors to suit specific requirements.

Multi-Point Indicator/Alarm Unit

RM-5000 Series



Multi-case



Single case (Buzzer unit)

Single case (Indicator/alarm unit)

Main areas of use

- Electronics
- Oil refining and petrochemicals
- Construction sites
- Steel plants
- Shipping and shipbuilding
- Firefighting and rescue
- Laboratories and universities
- Volcanic and hot spring sites
- Aerospace
- Food industry
- Miscellaneous
- Medical and nursing care / Paper industry / Printing and paints / AC and refrigeration equipment
- Energy / FCV and hydrogen stations / Environment and risk assessment

Detection target gases

- Depends on detector connected

Explosion-proof

- Explosion-proof
- Non-explosion-proof

RM-5000 features

- Supports a wide range of gas detector heads.
- Gas concentrations are displayed in two ways: bar meter and digital display.
- High-contrast 3-color LCD improves visibility of detection status.
- Equipped with RS-485 communication function (optional)

Specifications

Model	RM-5000
Alarm type	Gas alarm, fault alarm
Alarm pattern	Alarm lamp, buzzer sounding
Certification	CE marking (contact RIKEN KEIKI for corresponding models.)
Power source	24 V DC ± 10 %
External dimensions	Approx. 29.6 mm (W) × 120 mm (H) × 92 mm (D) (per unit)
Weight	Approx. 0.1 kg (per unit)
Operating temperature range	-10 to +40 °C (no sudden fluctuations)
Operating humidity range	10 to 90 %RH (no condensation)

Indicator/alarm unit - detector connection examples



The RM-5000 Series can be connected to the detector corresponding to the target gas.

The EC-/OX-/RM-5002 can be connected to 2-wire 4 to 20 mA transmission detectors, and the RM-5003 can be connected to 3-wire 4 to 20 mA transmission detectors.

Multi-Point Indicator/Alarm Unit

RM-590 Series



Multi-case



Single case (Indicator/alarm unit)

Single case (Buzzer unit)

RM-590 features

- Easy-to-read digital gas concentration display
- Selectable alarm patterns
- Allows low flow rate signal input.
- Can be connected to network (optional).

Specifications

Model	RM-590
Alarm pattern	Orange lamp (ALM1) flashing (steadily lit after confirmation) Red lamp (ALM2) flashing (steadily lit after confirmation)
Certification	CE marking (contact RIKEN KEIKI for corresponding models.)
Power source	24 V DC ± 10 %
External dimensions	Approx. 36 mm (W) × 72 mm (H) × 134 mm (D)
Weight	Approx. 0.1 kg (per unit)
Operating temperature range	0 to +40 °C (no sudden fluctuations)
Operating humidity range	10 to 90 %RH (no condensation)

Allows up to 12 gas detectors to be mounted.

Combustible Gas Detection Alarm System

GP-148



Main areas of use

- Electronics
- Oil refining and petrochemicals
- Construction sites
- Steel plants
- Shipping and shipbuilding
- Firefighting and rescue
- Laboratories and universities
- Volcanic and hot spring sites
- Aerospace
- Food industry
- Miscellaneous
- Medical and nursing care / Paper industry / Printing and paints / AC and refrigeration equipment
- Energy / FCV and hydrogen stations / Environment and risk assessment

Detection target gases

The detection target gases will vary depending on the particular model (specific sensor types installed).

Depends on detector connected

Explosion-proof

Explosion-proof Non-explosion-proof

Features

- Easy to read: At-a-glance identification of detection status
- Easy to use: Simple operation
- Peace of mind even in the event of a power outage: Built-in UPS allows continuous gas leak monitoring for at least three days even during a power outage, providing peace of mind in the event of a disaster.
- Permits combined monitoring using gas detectors and flame detectors.
- Allows required number of detection points to be selected (up to 12 points).
- Features 2 contacts: Enables combined use of revolving lights and buzzers.
- Ideal for combustible gas leak monitoring at LPG, CNG, and H₂ filling stations

Specifications

Model	GP-148
Alarm type	Gas alarm, fault alarm
Alarm pattern	Lamp lit + buzzer sounding (standard) or audible message (optional)
External output	General
	Individual
Power source	100 to 120 V AC or 200 to 240 V AC, 50/60 Hz
UPS ²	12 V 2.3 Ah lead-acid batteries × 2
External dimensions/weight (including approx. 1.9 kg of UPS)	2-point type: Approx. 305 mm (W) × 290 mm (H) × 73 mm (D) / Approx. 3.8 kg
	4-point type: Approx. 395 mm (W) × 290 mm (H) × 73 mm (D) / Approx. 4.9 kg
	6-point type: Approx. 485 mm (W) × 290 mm (H) × 73 mm (D) / Approx. 5.9 kg
	8-point type: Approx. 575 mm (W) × 290 mm (H) × 73 mm (D) / Approx. 6.4 kg
	10-point type: Approx. 665 mm (W) × 290 mm (H) × 73 mm (D) / Approx. 7.1 kg
	12-point type: Approx. 755 mm (W) × 290 mm (H) × 73 mm (D) / Approx. 7.9 kg
Operating temperature range	-10 to +50 °C (no sudden fluctuations)
Operating humidity range	10 to 90 %RH (no condensation)

*1: Choice of gas alarm contact + gas alarm contact or gas alarm contact + fault alarm contact
*2: When a type with UPS is selected.

Detection target gas list

Detection target gas	Isobutane	LPG	City gas	Methane	LNG	CNG	City gas	Methane	LNG	CNG
Displayed name	I-C ₄ H ₁₀	LPG	13 A	CH ₄	LNG	CNG	13 A	CH ₄	LNG	CNG
Detection range	100			100			12,500 (Display: "1250")			
Units	%LEL			%LEL			ppm			
1 digit	1			1			100			

Detection target gas	Hydrogen	Hydrogen	Propane	Toluene	Acetylene	Gasoline
Displayed name	H ₂	H ₂	C ₃ H ₈	C ₇ H ₈	C ₂ H ₂	GASOLINE
Detection range	100	2,000	100	100	100	100
Units	%LEL	ppm	%LEL	%LEL	%LEL	%LEL
1 digit	1	10	1	1	1	1

For information on other gases, please contact RIKEN KEIKI.

Uses independent units for easy mounting.

Single-Point Indicator/Alarm Unit

RM-6000 Series



GP-6001

(For combustible gas)

GP-6001 (W)

(For combustible gas)

SP-6001

(For combustible gas/toxic gas)

GH-6001

(For combustible gas/toxic gas)

EC-6002

(For toxic gas)

OX-6001/OX-6002

(For oxygen)

RM-6002/6003

(For 4 to 20 mA transmission)

RM-6003T

(For 4 to 30 mA transmission)

Specifications

Model	GP-6001 NC-6001 (W)	SP-6001	GH-6001	EC-6002	OX-6001	OX-6002	RM-6002	RM-6003	RM-6003T
Corresponding detector detection principle	Catalytic combustion type Catalytic type New ceramic type	Hot-wire semiconductor type	Semiconductor type	Electrochemical type Pyrolysis-particle type	Galvanic cell type		General measurement signal		Semiconductor type detector (GD-A44V)
Target gas	Combustible gas	Combustible gas, toxic gas		Toxic gas	Oxygen		Combustible gas, toxic gas, oxygen, etc. (General measurement signal)		Carbon monoxide
Detector signal	Direct sensor output signal			Current signal (4 to 20 mA DC)	Direct sensor output signal	Current signal (4 to 20 mA DC)		Current signal (4 to 30 mA DC)	
Alarm indications	1st: ALM1 red lamp flashing or lit (after resetting), buzzer sounding 2nd: ALM2 red lamp flashing or lit (after resetting), buzzer sounding								
Alarm contact	No voltage contact 1a or 1b each (2-stage independent), always de-energized (energized in alarm state) or always energized (de-energized in alarm state)								
Certification	CE marking (contact RIKEN KEIKI for corresponding models.)								
Power source	AC power type: 100 to 240 V AC ± 10 %, 50/60 Hz; DC power type: 24 V DC ± 10 % (21.6 to 26.4 V DC) (optional)								
Power consumption (excluding pump)	Max. 15 VA Max. 8.5 W (including detector)	Max. 11.5 VA Max. 6 W (including detector)	Max. 7.5 VA Max. 3.5 W (including detector)	Max. 6.5 VA Max. 3 W (including detector)	Max. 7.5 VA Max. 3.5 W (including detector)	Max. 7.5 VA Max. 3.5 W (including detector)	Max. 7.5 VA Max. 3.5 W (including detector)	Max. 7.5 VA Max. 3.5 W (including detector)	Max. 10.5 VA Max. 7.5 W (including detector)
External output	4 to 20 mA DC (non-insulated, load resistance 300 Ω or less) / Digital transmission: RS-485 (optional)								
External dimensions	Approx. 110 mm (W) × 190 mm (H) × 54 mm (D) (excluding projections)								
Weight	Wall-mounted type: 580 g, embedded type: 650 g								

Main areas of use

- Electronics
- Oil refining and petrochemicals
- Construction sites
- Steel plants
- Shipping and shipbuilding
- Firefighting and rescue
- Laboratories and universities
- Volcanic and hot spring sites
- Aerospace
- Food industry
- Miscellaneous
- Medical and nursing care / Paper industry / Printing and paints / AC and refrigeration equipment
- Energy / FCV and hydrogen stations / Environment and risk assessment

Detection target gases

The detection target gases will vary depending on the particular model (specific sensor types installed).

Depends on detector connected

Explosion-proof

Explosion-proof Non-explosion-proof

Features

- Compact, lightweight
- Gas concentrations are displayed in two ways: bar meter and digital display.
- Uses independent units for easy mounting.
- Two-stage alarm function allows sequential gas alarm management.
- Features maintenance mode function to disable external alarms during maintenance.

Easy-to-read 3-color LCD display

Gas concentrations are displayed simultaneously as bar meter and digital display. Names of gases are displayed in one of three colors to indicate the detection status. Allows to grasp detection status even from a distance.

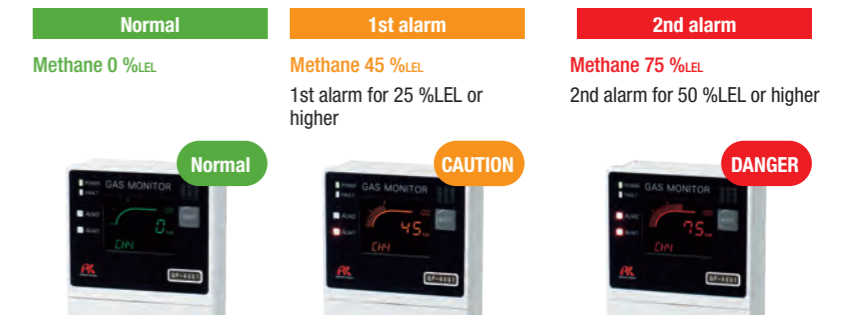

Gas Detection Alarm System

RIKEN KEIKI Kanshiro II

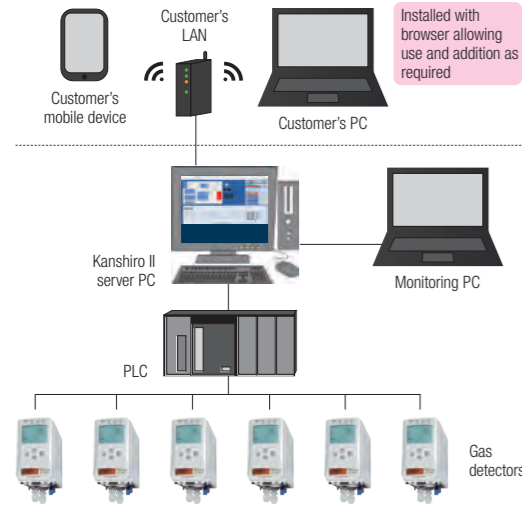

Installed with browser allowing use and addition as required

Main areas of use

- Electronics
- Oil refining and petrochemicals
- Construction sites
- Steel plants
- Shipping and shipbuilding
- Firefighting and rescue
- Laboratories and universities
- Volcanic and hot spring sites
- Aerospace
- Food industry
- Miscellaneous
- Medical and nursing care / Paper industry / Printing and paints / AC and refrigeration equipment
- Energy / FCV and hydrogen stations / Environment and risk assessment

Detection target gases

* The detection target gases will vary depending on the particular model (specific sensor types installed).

Depends on sensors unit installed

Features

Device: More versatile

- Customers can add their own monitoring PC.
- Customers can also use office PCs and mobile devices.

Interface: Closer to requirements

- Expanded search functions! Real-time full text free word searching from each display screen
- Completely new design and interface! Improved visual appeal and user friendliness

Information: More detailed

- Other gas detector information in addition to gas concentration and alarm status can be checked on the screen.
- Pump flow rate, battery level, sensor information, etc.

Alarm display screen

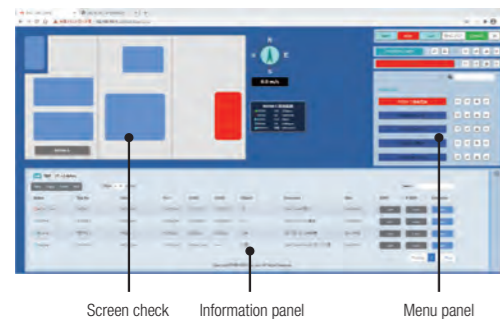

Screen check Information panel Menu panel

Information panel



List



Bar Graph



Alarm History

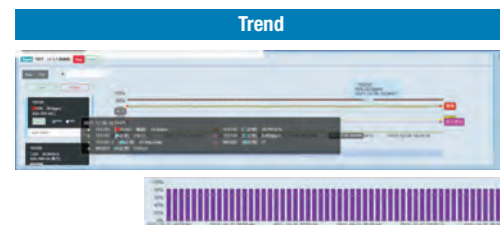

Trend

Map screen



The screen can be enlarged for ease of viewing even with small display sizes.

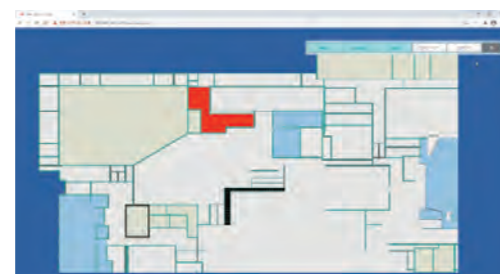

When an alarm occurs, the alarm area is indicated as shown on the left.

Specifications

System requirements	On-premise terminal (server)	CentOS7
	Client terminal (monitor)	Browser (Chrome, Edge recommended)
	Client communication method	Ethernet (LAN)
	Information collection and alarm control	PLC (Omron, Mitsubishi)
Functions/performance	Display configuration	Map (overall/individual), representative display panel, menu (each operation panel), information panel (List, Bar Graph, Alarm History, Trend)
	Alarm functions	Alarm display, sound playback, push notification
	Number of tags	Max. 60,000 * Up to approx. 1,000 tags per PCL
	Alarm history	Stores up to 100 million events.
	Trend	Stores up to 3 years of data (1-second sampling).
	Accounts	Allows registration of up to 1,000 accounts.
	Management functions	Enables/disables alarm check, alarm reset, alarm off, skip operation, and map display (restrictions) individually for each account.

Lineup features two types of more advanced multifunction pro specifications!

Photoemission Yield Spectroscopy in Air

AC-2S Series



Main areas of use

- Electronics
- Oil refining and petrochemicals
- Construction sites
- Steel plants
- Shipping and shipbuilding
- Firefighting and rescue
- Laboratories and universities
- Volcanic and hot spring sites
- Aerospace
- Food industry
- Miscellaneous
- Medical and nursing care / Paper industry / Printing and paints / AC and refrigeration equipment
- Energy / FCV and hydrogen stations / Environment and risk assessment

Measuring objects

Work function Ionization potential

Features

- Smaller and lower in price than previous models AC-2S
- Features high-intensity irradiation optical system exceeding 2 μW. AC-2S Pro α
- Features low-energy irradiation optical system capable of measuring from as low as 2 eV. AC-2S Pro β
- 400 μm square micro spot AC-2S Pro β
- Capable of high-temperature measurement at up to 100 °C AC-2S Pro α/AC-2S Pro β
- Film thickness measurement AC-2S Pro α/AC-2S Pro β
- Precision measurement in 0.01 eV steps AC-2S Pro α/AC-2S Pro β
- Features new irradiation optical system (LDLS lamp) AC-2S Pro β
- Includes often-requested multi-point measurement and repeated measurement functions.
- Allows analysis after importing AC-2/3/5 data.
- Uses flat-plate open counter to measure photoelectrons up to 4,000 cps.

Specifications

Model	AC-2S	AC-2S Pro α	AC-2S Pro β
Measuring principle	Photoemission yield spectroscopy in air (PYS) (Detector: Low-energy electron count method)		
Measurement energy scanning range	3.4 – 6.2 eV (364 – 200 nm)	2.0 – 6.2 eV (620 – 200 nm)	3.4 – 6.2 eV (364 – 200 nm)
Repeatability (standard deviation)	Work function 0.02 eV (sample: Gold sheet)		
Measurement time	Standard time required for work function measurement: Approx. 5 minutes* * Measurement energy scanning range: 4.2 – 6.2 eV, step: 0.1 eV, count time: 5 s per step		
Maximum count rate (CPS: Electron count per second)	4,000 cps		
UV lamp	Deuterium (D2) lamp	Laser-driven light source (LDLS)	
UV spot size	4 × 4 mm square or less	4 × 4 mm square or less	0.4 × 0.4 mm square or less
Spectrometer	Grating-type monochromator		
Sample size	50 × 50 mm (max.), thickness 10 mm (max.)		
Sample stage size	115 × 122 mm	120 × 122 mm heated sample stage	120 × 122 mm heated sample stage
Operating temperature range	+15 to 35 °C (no sudden fluctuations)		
Operating humidity range	0 to 60 %RH (no condensation)		
Power source	100 to 240 V AC, 50/60 Hz, 5 A (max.)	Main unit: 100 to 240 V AC, 50/60 Hz, 5 A (max.) LDLS (AC adapter): 100 to 240 V AC, 50/60 Hz, 2.5 A LDLS (main unit): 12 V DC 120 W Temperature controller: 100 V AC (± 10 %), 50/60 Hz, 1 A (max.)	
Dry compressed air supply conditions	0.1 to 0.2 MPa, 0.5 L/min (measurement), 2.0 L/min (purging)* * Separate conditions apply to the air supply. We recommend an optional compressor (sold separately). (Contact RIKEN KEIKI for more information.)		
External dimensions	LC (light source unit): Approx. 480 mm (W) × 317 mm (H) × 450 mm (D) DC (measuring unit): Approx. 465 mm (W) × 360 mm (H) × 450 mm (D)	LC (light source unit)*: Approx. 623 mm (W) × 317 mm (H) × 450 mm (D) DC (measuring unit): Approx. 465 mm (W) × 360 mm (H) × 450 mm (D) Temperature controller: Approx. 200 mm (W) × 163 mm (H) × 150 mm (D) * The LDLS power supply is housed in the LC (light source unit).	
Weight	AC-2S LC (light source unit): Approx. 25 kg AC-2S DC (measuring unit): Approx. 31 kg	AC-2S LC (light source unit): Approx. 30 kg AC-2S DC (measuring unit): Approx. 31 kg Temperature controller: Approx. 5 kg	

Function availability table

Function	AC-2S	AC-2S Pro α	AC-2S Pro β
Multi-point measurement	●	●	●
Repeated measurement	●	●	●
High-temperature measurement	—	●	●
Film thickness measurement	—	●	●
Long-life light source	—	●	●
Low-energy measurement	—	●	—
High light intensity measurement	—	●	—
Micro spot measurement	—	—	●
Consumable part replacement notification	●	●	●

Capable of measuring large/multiple samples

Photoemission Yield Spectroscopy in Air

AC-5



Features

- Measures work function and ionization potential in air in approximately 5 minutes.
- Capable of measuring large samples (max. 180 × 180 mm)
- Capable of continuous measurement (up to 25 at a time)
- Capable of measuring twice as many electrons per second as previous models (RIKEN KEIKI data)
- Energy scanning range: 3.4 – 6.2 eV

Main areas of use

Electronics	Oil refining and petrochemicals	Construction sites	Steel plants	Shipping and shipbuilding
Firefighting and rescue	Laboratories and universities	Volcanic and hot spring sites	Aerospace	Food industry
Miscellaneous	Medical and nursing care / Paper industry / Printing and paints / AC and refrigeration equipment / Energy / FCV and hydrogen stations / Environment and risk assessment			

Measuring objects

Work function	Ionization potential
---------------	----------------------

Specifications

Model	AC-5
Measuring principle	Photoemission yield spectroscopy in air (PYSA) (Detector: Low energy electron count method)
Photoelectron detector	Flat-plate open counter
UV energy range	3.4 – 6.2 eV
Minimum light intensity	1.0 nW or less (at 5.9 eV)
Maximum light intensity	500.0 nW or more (D2 lamp) / 2500.0 nW or more (optional Xe lamp) (at 5.9 eV)
Repeatability (standard deviation)	Work function 0.02 eV (sample: metal plate)
UV light source	D2 lamp/Xe lamp (optional)
UV spot size	4 × 4 mm or less (Varies depending on energy due to chromatic aberration of condensing lens.)
Maximum photoelectron count rate	4,000 cps
Spectrometer	Grating-type monochromator
Maximum sample size	Area 180 × 180 mm or less, thickness 1 mm ± 0.2 mm or less
Power source	100 to 240 V AC, 50/60 Hz, 5 A (max.) * Excluding control PC
External dimensions	Light source unit LC-1: Approx. 470 mm (W) × 300 mm (H) × 500 mm (D) Measuring unit DC-1: Approx. 600 mm (W) × 380 mm (H) × 500 mm (D)
Weight	Light source unit LC-1: Approx. 35 kg, measuring unit DC-1: Approx. 50 kg * Excluding control PC
Operating temperature range	+15 to 35 °C (no sudden fluctuations)
Operating humidity range	0 to 60 %RH (no condensation)

* A separate display and control system (PC) is required to operate this product.

Capable of measuring up to 7.0 eV in air

Photoemission Yield Spectroscopy in Air

AC-3



Features

- Samples are measured in air, allowing relatively large samples (max. 30 mm square) or powder samples to be measured as is.
- Capable of measuring surface information down to nanometer order depths
- Measures work function and ionization potential in approximately 5 minutes.
- Maximum light intensity: 100 nW or greater (at 5.9 eV)
- Handling is simple as vacuum is not used.

Main areas of use

Electronics	Oil refining and petrochemicals	Construction sites	Steel plants	Shipping and shipbuilding
Firefighting and rescue	Laboratories and universities	Volcanic and hot spring sites	Aerospace	Food industry
Miscellaneous	Medical and nursing care / Paper industry / Printing and paints / AC and refrigeration equipment / Energy / FCV and hydrogen stations / Environment and risk assessment			

Measuring objects

Work function	Ionization potential
---------------	----------------------

Specifications

Model	AC-3
Measuring principle	Photoemission yield spectroscopy in air (PYSA) (Detector: Low-energy electron count method)
Photoelectron detector	Double cylinder open counter
UV energy range	4.0 – 7.0 eV
Minimum light intensity	5.0 nW or less (at 5.9 eV)
Maximum light intensity	100.0 nW or more (at 5.9 eV)
Repeatability (standard deviation)	Work function 0.02 eV (sample: metal plate)
UV light source	D2 lamp
UV spot size	2 × 5 mm (No chromatic aberration due to use of concave mirror to focus light)
Maximum photoelectron count rate	2,000 cps
Spectrometer	Nitrogen substitution grating-type monochromator
Maximum sample size	Area 30 × 30 mm or less, thickness 10 mm or less
Power source	100 to 240 V AC, 50/60 Hz, 5 A (max.) * Excluding control PC
External dimensions	Approx. 740 mm (W) × 1,080 mm (M) × 680 mm (D) (including casters)
Weight	Approx. 120 kg * Excluding control PC
Operating temperature range	+15 to 35 °C (no sudden fluctuations)
Operating humidity range	20 to 60 %RH (no condensation)

* A separate display and control system (PC) is required to operate this product.

Kelvin probe specifically for flat plate samples (AC Series option)

Photoelectron Spectrometer Optional Fermi Level Measuring Unit

FAC-2



Features

- Allows measurement even of Fermi level in air for semiconductor samples not measurable with photoelectron spectrometers.
- Extremely fast measurement allows even time-dependent measurements such as of variations in metal surfaces immediately after coating formation.
- Easy sample mounting without fine adjustments of electrode/sample separation

Main areas of use

Electronics	Oil refining and petrochemicals	Construction sites	Steel plants	Shipping and shipbuilding
Firefighting and rescue	Laboratories and universities	Volcanic and hot spring sites	Aerospace	Food industry
Miscellaneous	Medical and nursing care / Paper industry / Printing and paints / AC and refrigeration equipment / Energy / FCV and hydrogen stations / Environment and risk assessment			

Measuring objects

Fermi level

Specifications

Model	FAC-2
Measuring principle	Kelvin method
Measuring unit size	φ10mm
Measurement energy range	3.4 – 6.2 eV (calibrated using standard sample with work function of 5.0 eV)
Measurement time	10 seconds or less (for metal samples)
Repeatability (standard deviation)	Work function 0.02 eV (sample: metal plate)
Power source	100 V AC, 50/60 Hz, 5 A (max.)
External dimensions	Approx. 235 mm (W) × 330 mm (H) × 408 mm (D) mm
Weight	Approx. 12 kg
Operating temperature range	+10 to 35 °C
Operating temperature range	20 to 60 %RH

Portable non-destructive non-contact analyzer

Portable X-ray Diffractometer with Fluorescent X-ray Analyzer

DF-01

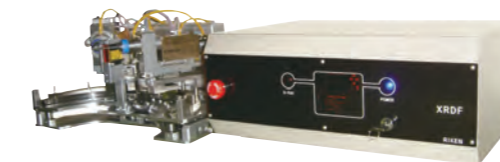

Features

- Both XRD and XRF analysis for the same point
Both X-ray diffraction (XRD) and X-ray fluorescence (XRF) analysis can be performed on the same point, enabling high accuracy information to be obtained from data measured by two different methods.
- Portable non-destructive non-contact analyzer
Allows on-site analysis using both X-ray diffraction (XRD) and X-ray fluorescence (XRF) of antiquities and cultural assets whose transport and carrying out are restricted.
- Measures large/irregular shape objects.
Capable of measuring objects of virtually any size or shape

Main areas of use

Electronics	Oil refining and petrochemicals	Construction sites	Steel plants	Shipping and shipbuilding
Firefighting and rescue	Laboratories and universities	Volcanic and hot spring sites	Aerospace	Food industry
Miscellaneous	Medical and nursing care / Paper industry / Printing and paints / AC and refrigeration equipment / Energy / FCV and hydrogen stations / Environment and risk assessment			

Measuring objects

Material surface analysis

Specifications

Model	DF-01
Measuring method	XRD, XRF
Elements detected	¹³ Al – ⁹² U (* XRF)
Sample configuration	No restrictions (* Must not impact the product.)
Atmosphere	Air/He
Measuring object size	φ2.5 mm or more (Varies depending on angle.)
Measurement range	0° – 120°
Minimum step	0.002°
Collimator	φ2 mm × 75 mm
X-ray tube target	Cr
X-ray tube rated output	28 W
X-ray tube rated voltage	35 kV
X-ray tube rated current	0.8 mA
X-ray tube cooling method	Forced air cooling
Detector	Si-PIN photodiode
Operation unit	PC
Power source	100 to 240 V AC, 50/60 Hz, 5 A (max.)
External dimensions	Measuring unit: 542 mm (W) × 203 mm (H) × 342 mm (D) (20 = 120°) Control unit: 427 mm (W) × 180 mm (H) × 295 mm (D)
Weight	Measuring unit: Approx. 12 kg Control unit: Approx. 16 kg (excluding cables and PC)

* A separate display and control system (PC) is required to operate this product.

Accessories

The detector units of gas alarms are installed in locations associated with potential gas leaks or gas accumulations, which may include a wide range of different environments. When installed outdoors, rainwater, dust, or flooding inside pits may significantly impair gas alarm functions due to blockage or water ingress inside the detector. RIKEN KEIKI provides a range of pre-processing accessories suited to individual environments in which detectors are installed.

Combustible Gas Detector Head

SD-3 Series



Sunshade cover

Splash guard

Duct mounting kit

Combustible Gas Detector Head

GD-A80 Series

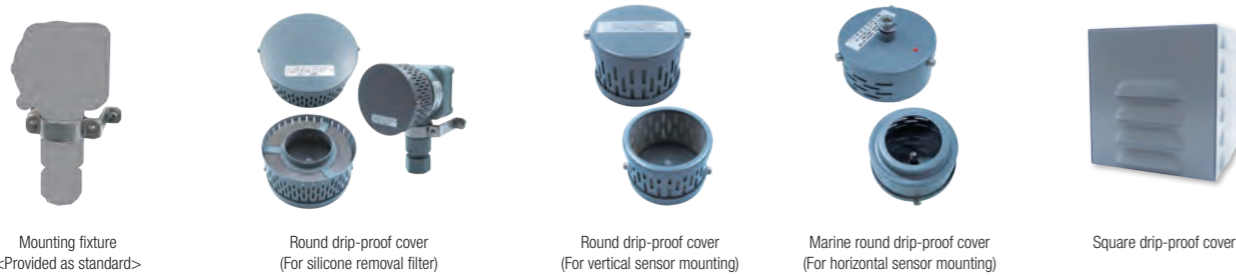

Mounting fixture
<Provided as standard>

Round drip-proof cover
(For silicone removal filter)

Round drip-proof cover
(For vertical sensor mounting)

Marine round drip-proof cover
(For horizontal sensor mounting)

Square drip-proof cover

Flame-proof Suction Type Gas Detector

GD-D58 Series



MC filter with flow monitor
<Provided as standard>

Gas inlet

Sunshade cover

Protective cover

Combustible Gas Smart Transmitter/Gas Detector

SD-1 Series



Round drip-proof cap

Splash guard

Sunshade cover
(For mounting on wall or pipe)

Protective cover

Filters



Dust removal filter

Charcoal filter
(For solvent/adsorption gas removal)

Trap filter

Silicone removal filter

Marine Gas Detection Alarm Systems

◆ Scanning Gas Detection Alarm System

For pump rooms, water ballast tanks, inter-barrier spaces, and other holds

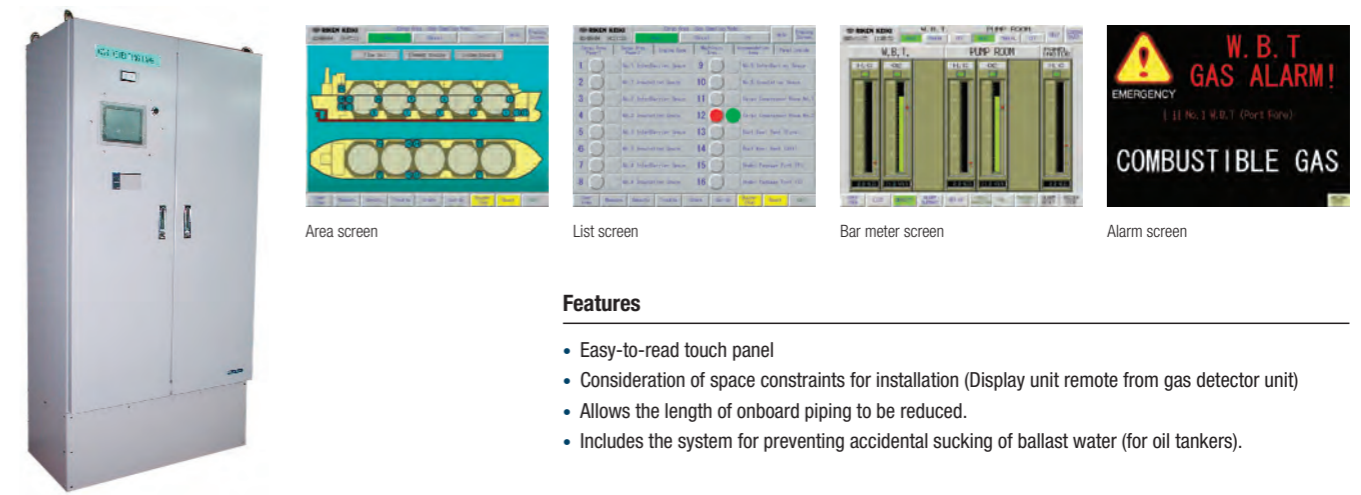

Area screen

List screen

Bar meter screen

Alarm screen

Features

- Easy-to-read touch panel
- Consideration of space constraints for installation (Display unit remote from gas detector unit)
- Allows the length of onboard piping to be reduced.
- Includes the system for preventing accidental sucking of ballast water (for oil tankers).

◆ Gas Sampling System

RS series



Features

- NK certified gas sampling system for safety monitoring of adjacent zones in cargo tanks of oil tankers of 20,000 DWT or over
- Series consisting of four types suited for each type of vessel
- RS-40: 40 to 21 point selection
- RS-30: 30 to 21 point selection
- RS-20: 24 to 11 point selection
- RS-10: Up to 10 point selection
- Standardized design for reduced lead times and stable supply
- Infrared type sensor enables measurement even in inert atmospheres.

Allows up to six points to be detected using a single gas detector.

◆ Sample Gas Selector

SM-6D
SM-6DS (corrosion-resistant model)



Specifications

Model	SM-6D/SM-6DS (SUS model)
Number of sampling points	6 points (2, 3, 4, or 5 points can also be set)
Sampling pump	Built-in, suction flow rate 3 L/min or more (with no load, 20 °C ambient temperature)
Sampling time	Standard 120 seconds/point (preliminary suction 80 seconds + main suction 40 seconds)
Alarm type	1st gas alarm: Yellow lamp indication (for each point) 2nd gas alarm: Red lamp indication (for each point) Alarm buzzer: Sounds for 1st and 2nd gas alarms.
External contact output	1st gas alarm: 1a contact (for each point) 2nd gas alarm: 1a contact (for each point) General alarm: 1a contact (for alarm or fault) Contact capacity: 125 V AC, 0.5 A (resistance load)
Operating temperature/humidity range	-10 to +40 °C, up to 90 %RH (no condensation)
Power source (power consumption)	100 V AC ± 10 %, 50/60 Hz (approx. 95 VA)
External dimensions/weight	Approx. 366 mm (W) × 354 mm (H) × 196 mm (D) / Approx. 16 kg

Gas Hazards

What are combustible gases?

The Safety Regulations for General High Pressure Gas define **combustible gases** as follows:

- Gases with a lower explosive limit (the explosive limit when mixed with air) of 10 % or lower
- Gases for which the difference between the lower and upper explosive limits is 20 % or greater

Combustible gas is the general name given to gases that may cause combustion. Combustible gases may cause explosion if the oxygen (air) gas mixture is within a specific concentration range and in the presence of an ignition source. This concentration range is referred to as the explosive range, **the minimum concentration within this explosive range is referred to as the lower explosive limit (LEL), and the maximum concentration is referred to as the upper explosive limit (UEL).**

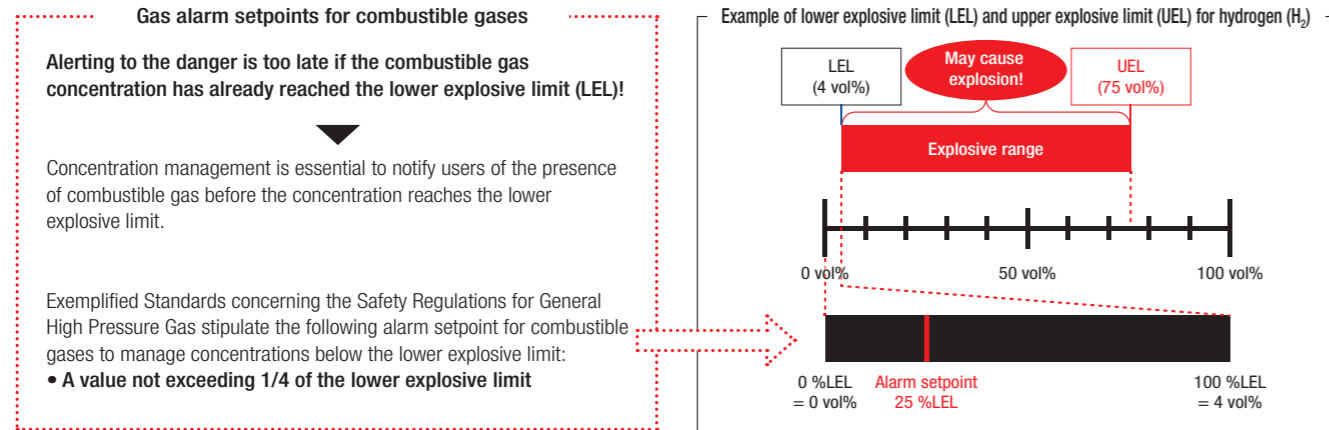

◆ Detection target combustible gas list

Substance name	Chemical formula	Flash point (°C)	Ignition point (°C)	Explosive limit (vol%)		Vapor density
				Lower limit	Upper limit	
Acetylene	C ₂ H ₂	gas	305	1.5	100	0.9
Acetone	C ₃ H ₆ O	-20	539	2.15	14.3	2.0
Isobutane	C ₄ H ₁₀	gas	460	1.8	9.8	2.0
Ethanol	C ₂ H ₆ O	12	400	3.3	19	1.6
Ethane	C ₂ H ₆	gas	515	3.0	15.5	1.0
Ethylene	C ₂ H ₄	gas	440	2.7	36.0	1.0
o-Xylene	C ₈ H ₁₀	30	470	1.0	7.6	3.7
Ethyl acetate	C ₄ H ₈ O ₂	-4	470	2.1	12.8	3.0
Cyclohexane	C ₆ H ₁₂	-17	245	1.3	8.3	2.9
Cyclopentane	C ₅ H ₁₀	-37	320	1.4	—	2.4
Dimethyl ether	C ₂ H ₆ O	gas	240	3.0	32	1.6
Hydrogen	H ₂	gas	560	4.0	75	0.1
Styrene	C ₈ H ₈	30	490	1.1	8.0	3.6
Tetrahydrofuran	C ₄ H ₈ O	-14	230	2.0	12.4	2.5
Toluene	C ₇ H ₈	4	530	1.2	7.8	3.1
1,3-butadiene	C ₄ H ₆	gas	420	1.1	16.3	1.9
Propane	C ₃ H ₈	gas	450	2.0	10.9	1.6
Propylene	C ₃ H ₆	gas	455	2.0	11.1	1.5
n-Hexane	C ₆ H ₁₄	-22	223	1.2	7.5	3.0
n-Heptane	C ₇ H ₁₆	-7	204	1.1	6.7	3.5
Benzene	C ₆ H ₆	-11	498	1.2	8.6	2.7
Methyl methacrylate	C ₅ H ₈ O ₂	10	430	1.7	12.5	3.6
Methanol	CH ₃ O	9	440	5.5	36	1.1
Methane	CH ₄	gas	600	5.0	15.0	0.6
Methyl isobutyl ketone	C ₆ H ₁₂ O	16	475	1.2	8.0	3.5

* Individual values may vary depending on the source.

Reference: Technical Recommendation of National Institute of Occupational Safety and Health JNOSH-TR-No.44 (2012) Users' Guidelines for Installations for Explosive Atmospheres in General Industry (Issued November 1, 2012)

However, lower explosive limit values are provided based on RIKEN KEIKI internal standards.

What are toxic gases?

The Safety Regulations for General High Pressure Gas define **toxic gases** as follows:

- Gases such as acrylonitrile, acrolein, sulfur dioxide, arsine, ammonia, carbon monoxide, chlorine, chloromethyl, chloroprene, arsenic pentafluoride, phosphorus pentafluoride, ethylene oxide, nitrogen trifluoride, boron trifluoride, phosphorus trifluoride, hydrogen cyanide, diethylamine, disilane, sulfur tetrafluoride, silicon tetrafluoride, diborane, hydrogen selenide, trimethylamine, carbon disulfide, fluorine, methyl bromide, benzene, phosgene, phosphine, monogermene, monosilane, monomethylamine, and hydrogen sulfide, which are toxic substances as stipulated in Article 2, paragraph (1) of the Poisonous and Deleterious Substances Control Act (Act No. 303 of 1950)

Similarly, the Exemplified Standards concerning the Safety Regulations for General High Pressure Gas describe alarm setpoints for toxic gases as follows:

- Values not exceeding the allowable concentration (two times the allowable concentration in cases in which preparing the calibration gas is impractical)

◆ Definition of acceptable concentration

Airborne concentrations of chemical substances under which it is believed that **nearly all workers may be repeatedly exposed in the workplace without adverse effects**

Acceptable concentrations are recommended by the ACGIH (American Conference of Governmental Industrial Hygienists) and the Japan Society for Occupational Health, and **RIKEN KEIKI uses the ACGIH acceptable concentrations.**

◆ Types of acceptable concentrations

TWA (Time Weighted Average)	The time-weighted average concentration for a conventional 8-hour workday and a 40-hour work week, to which it is believed that workers may be repeatedly exposed without adverse effect
STEL (Short-Term Exposure Limit)	A short-term exposure limit for which no adverse effects are experienced, provided exposure does not exceed 15 minutes, with at least 60 minutes between successive exposures, and occurs no more than four times per day
C (Ceiling value)	The upper limit that must not be exceeded

Carbon monoxide (CO)

Carbon monoxide combines with the hemoglobin inside red blood cells, blocking oxygen transport within the body. Exposure produces symptoms of poisoning. These symptoms include headache, nausea, dizziness, tinnitus, perspiration, and general fatigue.

◆ CO chemical properties:

- Colorless, odorless gas
- Poorly soluble in water
- Molecular weight: 28
- Specific gravity: 0.97 (virtually identical to air)
- TLV: 25 ppm (ACGIH: American Conference of Government Industrial Hygienists)
- Lower explosive limit (LEL): 12.5 vol%

◆ Carbon monoxide inhalation time and poisoning symptoms

CO concentration in the air	Inhalation time and poisoning symptoms
0.02 % (200 ppm)	Mild frontal headache within 2 to 3 hours
0.04 % (400 ppm)	Frontal headache and nausea within 1 to 2 hours; occipital headache within 2.5 to 3.5 hours
0.08 % (800 ppm)	Headache, dizziness, nausea, and convulsions within 45 minutes; loss of consciousness within 2 hours
0.16 % (1,600 ppm)	Headache, dizziness, and nausea within 20 minutes; death within 2 hours
0.32 % (3,200 ppm)	Headache and dizziness within 5 to 10 minutes; death within 30 minutes
0.64 % (6,400 ppm)	Headache and dizziness within 1 to 2 minutes; death within 15 to 30 minutes
1.28 % (12,800 ppm)	Death within 1 to 3 minutes

Source: FY2020 project on CO poisoning prevention technologies commissioned by METI

◆ Detection target toxic gas list

Detection target gas	Chemical formula	ACGIH guidelines			Japan Society for Occupational Health guidelines Acceptable concentration ¹	RIKEN KEIKI standards	
		Acceptable concentration (TLV) ¹				Detection range ²	Alarm setpoint ²
		TWA	STEL	C			
Arsine	AsH ₃	5 ppb	—	—	0.01 ppm	0 – 50 ppb	10 ppb
Phosphine	PH ₃	0.05 ppm	—	0.15 ppm	0.3 ppm	0 – 0.15 ppm	0.05 ppm
Diborane	B ₂ H ₆	0.1 ppm	—	—	0.01 ppm	0 – 0.3 ppm	0.1 ppm
Silane	SiH ₄	5 ppm	—	—	100 ppm	0 – 15 ppm	5 ppm
Disilane	Si ₂ H ₆	—	—	—	—	0 – 15 ppm	5 ppm
Germane	GeH ₄	0.2 ppm	—	—	—	0 – 0.8 ppm	0.2 ppm
Hydrogen selenide	H ₂ Se	0.05 ppm	—	—	0.05 ppm	0 – 0.2 ppm	0.05 ppm
Nitrogen trifluoride	NF ₃	10 ppm	—	—	—	0 – 30 ppm	10 ppm
Boron tribromide	BBr ₃	—	—	0.7 ppm	—	HBr 0 – 6 ppm	HBr 2 ppm
Arsenic trichloride	AsCl ₃	—	—	—	—	HCl 0 – 6 ppm	HCl 2 ppm
Arsenic pentachloride	AsCl ₅	—	—	—	—	HCl 0 – 6 ppm	HCl 2 ppm
Boron trichloride	BCl ₃	—	—	0.7 ppm	—	HCl 0 – 6 ppm	HCl 2 ppm
Germanium tetrachloride	GeCl ₄	—	—	—	—	HCl 0 – 6 ppm	HCl 2 ppm
Molybdenum pentachloride	MoCl ₅	—	—	—	—	HCl 0 – 6 ppm	HCl 2 ppm
Phosphorus trichloride	PCl ₃	0.2 ppm	0.5 ppm	—	0.2 ppm	HCl 0 – 6 ppm	HCl 2 ppm
Phosphorus pentachloride	PCl ₅	0.1 ppm	—	—	0.1 ppm	HCl 0 – 6 ppm	HCl 2 ppm
Phosphorus oxychloride	POCl ₃	0.1 ppm	—	—	—	HCl 0 – 6 ppm	HCl 2 ppm
Antimony pentachloride	SbCl ₅	—	—	—	—	HCl 0 – 6 ppm	HCl 2 ppm
Silicon tetrachloride	SiCl ₄	—	—	—	—	HCl 0 – 6 ppm	HCl 2 ppm
Dichlorosilane	SiH ₂ Cl ₂	—	—	—	—	HCl 0 – 6 ppm	HCl 2 ppm
Trichlorosilane	SiHCl ₃	—	—	—	—	HCl 0 – 6 ppm	HCl 2 ppm
Tin tetrachloride	SnCl ₄	—	—	—	—	HCl 0 – 6 ppm	HCl 2 ppm
Tungsten hexachloride	WCl ₆	—	—	—	—	HCl 0 – 6 ppm	HCl 2 ppm
Tungsten hexafluoride	WF ₆	—	—	—	—	HF 0 – 1.5 ppm	HF 0.5 ppm
Arsenic trifluoride	AsF ₃	—	—	—	—	HF 0 – 1.5 ppm	HF 0.5 ppm
Arsenic pentafluoride	AsF ₅	—	—	—	—	HF 0 – 1.5 ppm	HF 0.5 ppm
Boron trifluoride	BF ₃	0.1 ppm	—	0.7 ppm	0.3 ppm	HF 0 – 1.5 ppm	HF 0.5 ppm
Molybdenum hexafluoride	MoF ₆	—	—	—	—	HF 0 – 1.5 ppm	HF 0.5 ppm
Phosphorus pentafluoride	PF ₅	—	—	—	—	HF 0 – 1.5 ppm	HF 0.5 ppm
Sulfur tetrafluoride	SF ₄	—	—	0.1 ppm	—	HF 0 – 1.5 ppm	HF 0.5 ppm
Silicon tetrafluoride	SiF ₄	—	—	—	—	HF 0 – 1.5 ppm	HF 0.5 ppm
Hydrogen chloride	HCl	—	—	2 ppm	2 ppm	0 – 6 ppm	2 ppm
Hydrogen fluoride	HF	0.5 ppm	—	2 ppm	3 ppm	HF 0 – 1.5 ppm	HF 0.5 ppm
Hydrogen bromide	HBr	—	—	2 ppm	—	0 – 6 ppm	2 ppm
Hydrogen iodide	HI	—	—	—	—	0 – 5 ppm	1.5 ppm
Chlorine	Cl ₂	0.1 ppm	0.4 ppm	—	0.5 ppm	0 – 0.3 ppm	0.1 ppm
Fluorine	F ₂	0.1 ppm	—	0.5 ppm	—	0 – 3 ppm	1 ppm
Bromine	Br ₂	0.1 ppm	0.2 ppm	—	0.1 ppm	0 – 1 ppm	0.3 ppm
Chlorine trifluoride	ClF ₃	—	—	0.1 ppm	—	0 – 0.3 ppm	0.1 ppm
Ozone	O ₃	0.1 ppm	—	—	0.1 ppm	0 – 0.6 ppm	0.1 ppm
Nitrogen monoxide	NO	25 ppm	—	—	—	0 – 100 ppm	25 ppm
Nitrogen dioxide	NO ₂	0.2 ppm	—	—	Pending	0 – 9 ppm	3 ppm
Sulfur dioxide	SO ₂	—	0.25 ppm	—	Pending	0 – 6 ppm	2 ppm
Hydrogen sulfide	H ₂ S	1 ppm	5 ppm	—	5 ppm	0 – 3 ppm	1 ppm
Carbon monoxide	CO	25 ppm	—	—	50 ppm	0 – 75 ppm	25 ppm
Ammonia	NH ₃	25 ppm	35 ppm	—	25 ppm	0 – 75 ppm	25 ppm
Monomethylamine (MMA)	CH ₃ N	5 ppm	15 ppm	—	10 ppm	0 – 15 ppm	5 ppm
Dimethylamine (DMA)	C ₂ H ₇ N	5 ppm	15 ppm	—	2 ppm	0 – 15 ppm	5 ppm
Trimethylamine (TMA)	C ₃ H ₉ N	5 ppm	15 ppm	—	—	0 – 15 ppm	5 ppm
Diethylamine (DEA)	C ₄ H ₁₁ N	5 ppm	15 ppm	—	10 ppm	0 – 15 ppm	5 ppm
Hydrogen cyanide	HCN	—	—	4.7 ppm	5 ppm	0 – 15 ppm	4 ppm
Hydrogen peroxide	H ₂ O ₂	1 ppm	—	—	—	0 – 3 ppm	1 ppm

*1: For more information on acceptable concentrations recommended by the ACGIH (American Conference of Government Industrial Hygienists), refer to "2022 TLVs R and BEIs R". For more information on acceptable concentrations recommended by the Japan Society for Occupational Health, refer to the *Journal of Occupational Health*, Vol. 61 No. 5, May 2019. RIKEN KEIKI uses ACGIH acceptable concentrations.
TWA: Time Weighted Average (The time-weighted average concentration for a conventional 8-hour workday and a 40-hour work week, to which it is believed that workers may be repeatedly exposed without adverse effect)
STEL: Short Term Exposure Limit (A short-term exposure limit for which no adverse effects are experienced, provided exposure does not exceed 15 minutes, with at least 60 minutes between successive exposures, and occurs no more than four times per day)
C: Ceiling (Concentration that must not be exceeded even momentarily. Upper limit.)
*2: For gases that hydrolyze, the detection range and alarm setpoints are indicated for the gases produced after hydrolysis of the detection target gas.

What are anoxia and hydrogen sulfide poisoning?

The Ordinance on Prevention of Anoxia, etc. defines anoxia and hydrogen sulfide poisoning as follows:

• Anoxia

The state in which symptoms are observed due to inhalation of air of oxygen concentration below 18 %

• Hydrogen sulfide poisoning

The state in which symptoms are observed due to inhalation of air of hydrogen sulfide concentration exceeding 10 parts per million (10 ppm)

Normal alarm setpoints are set to 18 % in accordance with the Ordinance on Prevention of Anoxia, etc.

Oxygen deficiency symptoms

Oxygen concentration (%)	Symptoms
20.93	Atmospheric oxygen concentration
18	Lower safety limit; continuous ventilation, oxygen concentration measurement, safety harnesses, and protective breathing equipment must be provided in the work environment.
16 – 12	Increased pulse and respiration rate, impaired concentration, errors in simple arithmetic, impaired manual dexterity, impaired muscular strength, headache, tinnitus, retching, nausea
14 – 9	Impaired judgment, elation, unstable mental state, frequent sighing, abnormal fatigue, inebriation, headache, nausea, vomiting, loss of current memory, loss of feeling of pain, general weakness, increased body temperature, cyanosis, stupor, risk of death due to falling from steps/ladders or drowning
10 – 6	Nausea, vomiting, loss of ability to move freely, inability to move or call out for help, collapse, hallucination, cyanosis, loss of consciousness, fainting, central nervous system disorder, generalized convulsions, risk of death
6 or less	A few gasping breaths followed by fainting/loss of consciousness, slowed/stopped respiration, convulsions, heart arrest, death

Reference: New textbook for operations chiefs of hazardous work of oxygen deficiency (3rd edition, October 26, 2007)

Hydrogen sulfide poisoning symptoms

Hydrogen sulfide concentration (ppm)	Symptoms
0.025	Threshold of odor perception
0.2	Unmistakable odor
3 – 5	Moderately unpleasant odor
10	Lower limit for irritation to eyes
20 – 30	Inability to sense intensity for higher concentrations due to becoming accustomed with odor Lower limit for irritation to lungs
100 – 300	Paralysis of olfactory sense within 2–15 minutes reduces sense of unpleasant odor. Keratoconjunctivitis ("gas eye"), itchy eyes, pain, feeling of sand in eyes, sensation of brightness, bloodshot/swollen eyes, membrane opacity, retinal damage/separation, distorted/cloudy vision, increased pain due to light Continuous exposure for 8–48 hours leads to bronchial inflammation, pneumonia, and suffocation due to pulmonary edema. Burning pain in airway membranes Limit for serious symptoms provided exposure does not exceed 1 hour
350 – 600	Risk of death due to exposure between 30 minutes and 1 hour.
700 – 1,000	Short-interval respiration immediately followed by respiratory paralysis, loss of consciousness, fainting, respiratory arrest, and death
5,000	Immediate death

The importance of maintenance

Gas detector maintenance performed at regular intervals is critical maintaining product performance and to improving reliability in terms of disaster prevention and safety. Continuing to use the product without maintenance will prevent accurate detection.

Maintenance comprises daily and monthly maintenance performed by workers and regular maintenance performed by RIKEN KEIKI service engineers. Daily maintenance consists of visual checks performed by workers before commencing work. Monthly maintenance consists of checking (alarm testing) of the alarm circuits performed by workers. Regular maintenance involves maintenance such as span adjustment performed once every six months to maintain product performance as a safety device.

Proper maintenance will contribute to maintaining device performance and function for extended periods and ensuring safety against gas-related disasters.



Related Laws and Regulations (JAPAN)

In the work environments where combustible gases, toxic gases and other hazardous gases are used, it is mandatory to install gas detector to measure them in order to secure safety. This section provides excerpt of the laws and regulations relating to gas detector.

High Pressure Gas Safety Act

(act no. 204 of June 7, 1951)

Latest Amendments: Act No. 42 of June 2, 2017

Chapter I General Provisions

Article 1 (purpose)

The purpose of this Act is to regulate the production, storage, sale, transportation and other matters related to the handling of high pressure gases, their consumption as well as the manufacture and handling of their containers and to encourage voluntary activities by private businesses and the High Pressure Gas Safety Institute of Japan for the safety of high pressure gases with the aim of securing public safety by preventing accidents and disasters caused by high pressure gases.

Article 2 (definitions)

The term "high pressure gas" as used in this Act means any gas that falls under any of the following items:

- Compressed gas, the pressure (meaning gauge; the same shall apply hereinafter) of which is not less than 1 megapascal at its normal operating temperature and which is currently not less than 1 megapascal, or compressed gas, the pressure of which is not less than 1 megapascal at a temperature of 35 degrees Celsius (except compressed acetylene gas in both cases);
- Compressed acetylene gas, the pressure of which is not less than 0.2 megapascal at its normal operating temperature and which is currently not less than 0.2 megapascal, or compressed acetylene gas, the pressure of which is not less than 0.2 megapascal at a temperature of 15 degrees Celsius;
- Liquefied gas, the pressure of which is not less than 0.2 megapascal at its normal operating temperature and which is currently not less than 0.2 megapascal, or liquefied gas, the temperature of which is 35 degrees Celsius or less in the case that the pressure is 0.2 megapascal; or
- In addition to what is listed in the preceding item, those liquefied gases, the pressure of which exceeds zero Pascal at a temperature of 35 degrees Celsius, and which, inclusive of liquefied hydrogen cyanide and liquefied methyl-bromide, are specified by a Cabinet Order.

Cabinet Order of High Pressure Gas Safety Act

(cabinet order no. 20 of February 19, 1997)

Latest Amendments: Cabinet Order No. 198 of July 20, 2017

Article 7 (type of high pressure gas specified in cabinet order)

The types of gases, among those high pressure gases of Paragraph 1 of Article 24-2 of the Act, specifically specified in a Cabinet Order as requiring special care for the prevention of accidents in their consumption shall be the following gases in compressed and liquefied form:

- silane
- phosphine
- arsine
- diborane
- hydrogen selenide
- monogermene
- disilene

Safety Regulations for General High Pressure Gas

(ministry of international trade and industry ordinance no. 53 of May 25, 1966)

Latest Amendments: Ministry of Economy, Trade and Industry Ordinance No. 48 of July 17, 2018

Chapter I General Provisions

Article 1 (scope)

This is to set forth, based on the High Pressure Gas Safety Act (act no. 204 of 1951, hereinafter referred to as the "Act"), the regulations on the safety (excluding the safety on the production of high pressure gases pertaining to the specific production businesses specified in the Safety Regulations for Industrial Complex, etc. (ministry of international trade and industry ordinance no. 88 of 1986)) on the high pressure gases (excluding high pressure gases subject to the provisions of Regulations for Refrigeration Safety (ministry of international trade and industry ordinance no. 51 of 1966) and Safety Regulations for Liquefied Petroleum Gas (ministry of international trade and industry ordinance no. 52 of 1966): the same shall apply hereinafter).

Article 2 (definitions)

For the purpose of these regulations, the terms listed in the following items shall be defined as follows:

- "combustible gases" shall mean: acrylonitrile, acrolein, acetylene, acetaldehyde, arsine, ammonia, carbon monoxide, ethane, ethylamine, ethyl benzene, ethylene, ethyl chloride, vinyl chloride, chloromethyl, ethylene oxide, propylene oxide, hydrogen cyanide, cyclopropane, disilene, diborane, dimethylamine, hydrogen, hydrogen selenide, trimethylamine, carbon disulfide, butadiene, butane, butylene, propane, propylene, bromomethyl, benzene, phosphine, methane, monogermene, silane, monomethylamine, methyl ether, hydrogen sulfide and other gases falling under either of the following a. or b.(except Fluoroolefin 1234yf and Fluoroolefin 1234ze)
 - the lower explosion limit (meaning the explosion limit when mixed with air: the same shall apply hereinafter) being 10% or less
 - the difference between the upper limit and lower explosion limit being 20% or more

- "toxic gases" shall mean: acrylonitrile, acrolein, sulfuric acid gas, arsine, ammonia, carbon monoxide, chlorine, chloromethyl, chloroprene, arsenic pentafluoride, phosphorus pentafluoride, ethylene oxide, nitrogen trifluoride, boron trifluoride, phosphorus trifluoride, hydrogen cyanide, diethylamine, disilene, sulfur tetrafluoride, silicon tetrafluoride, diborane, hydrogen selenide, trimethylamine, carbon disulfide, fluorine, bromomethyl, benzene, phosgene, phosphine, monogermene, silane, monomethylamine, hydrogen sulfide and other gases with poisonous substances provided in Article 2, paragraph (1) of Poisonous and Deleterious Substances Control Act.
- "special high pressure gases" shall mean: arsine, disilene, diborane, hydrogen selenide, phosphine, monogermene and silane.
- "inert gases" shall mean: helium, neon, argon, krypton, xenon, radon, nitrogen, carbon dioxide or fluorocarbon (excluding combustible gases).

Chapter II Permission, etc. concerning Production or Storage of High Pressure Gas

Section 1 Permission, etc. concerning Production of High Pressure Gas

Article 6 (technical standards concerning stationary production equipment)

Technical standards specified by an Ordinance of METI as referred to in Article 8, item (1) of the Act for the production facilities made up of stationary production equipment (excluding cold evaporator, compressed natural gas station, liquefied natural gas station and compressed hydrogen station) shall be as follows, provided, however, that this shall not apply in case of taking any safety measure which is approved by the Minister of Economy, Trade and Industry as having an equivalent effect, and refrigerating equipment for cooling of production equipment may be subject to the technical standards specified by the Regulations for Refrigeration Safety.

- Electrical equipment concerning high pressure gas equipment for combustible gases (excluding ammonia and bromomethyl) shall be of a structure having explosion-proof capabilities suitable for its installation place and the type of the gas.
- Production facilities of combustible gases, toxic gases (limited to gases specified by the Minister of Economy, Trade and Industry in the public notice) or specific inert gases shall be installed with equipment to detect leak of such gases and trigger an alarm at places where gases leaked from such production facilities may accumulate.
- Piping concerning gas equipment for special high-pressure gas, arsenic pentafluoride, etc., sulfuric acid gas, ammonia, chlorine, chloromethyl, ethylene oxide, hydrogen cyanide, phosgene or hydrogen sulfide shall, wherever necessary, of double tube construction depending on the type, properties and pressure of these gases as well as on the nearby situation of the piping (including the concentrated condition of type 1 safety properties and type 2 safety properties in the vicinity of the business where the piping is installed), and necessary measures shall be taken to detect the leakage of the gas from such double tube, provided, however, that this shall not apply if the piping is prevented from being damaged by installing in a sheath or other protective structure and measures are taken to prevent any leaked gas from spreading to the vicinity.

Chapter VIII Notification concerning Consumption of High Pressure Gas

Article 55 (technical standards concerning consumers of specific high pressure gas)

Technical standards specified by an Ordinance of METI as referred to in Paragraph 1 of Article 24-3 of the Act shall be as follows.

- Piping concerning consumption equipment for special high-pressure gas, liquefied ammonia or liquefied chloride shall, wherever necessary, of double tube construction depending on the type, properties and pressure of these gases as well as on the nearby situation of the piping (including the concentrated condition of type 1 safety properties and type 2 safety properties in the vicinity of the business where the piping is installed), and necessary measures shall be taken to detect the leakage of the gas from such double tube, provided, however, that this shall not apply if the piping is prevented from being damaged by installing in a sheath or other protective structure and measures are taken to prevent any leaked gas from spreading to the vicinity.
- Consumption facilities shall be installed with equipment to detect leak of such gases and trigger an alarm at places where gases leaked from such production facilities may accumulate.

Exemplified Standards concerning Safety Regulations for General High Pressure Gas

(enacted on March 26, 2001, amended on July 1, 2019)

23. Gas leakage detection and alarm equipment and place of installation

Relevant provisions

Article 6 paragraph 1 item (xxxi), Article 7 paragraph 1 item (i), Article 7-3 paragraph 1 item (vii), paragraph 2 item (xvi), Article 12 paragraph 1 item (i), Article 8-2 paragraph 1 item (i), paragraph 2 item (ii) a, Article 12 paragraph 1 item (i), Article 12-2 paragraph 1 item (i), paragraph 2 item (i), Article 12-3 paragraph 1 item (i), paragraph 2 item (iii) a, Article 22 the main sentence, item (ii), item (iii), Article 22, Article 55 paragraph 1 item (xxvi)

Equipment to detect and trigger an alarm of any leakage of combustible gases and toxic gases (acrylonitrile, sulfuric acid gas, arsine, ammonia, carbon monoxide, chlorine, ethylene oxide, disilene, diborane, hydrogen selenide, carbon disulfide, benzene, phosphine, monogermene, silane and hydrogen sulfide) or specific inert gases at production facilities, storage places and consumption facilities shall be in accordance with the following standards.

1. Function

Gas leakage detection and alarm equipment (hereinafter referred to as "Detection alarm equipment" in 23 of these Standards) shall be capable of detecting leakage of combustible gases, oxygen, toxic gases or specific inert gases, indicating its concentration as well as triggering an alarm and shall have the following capabilities.

- Detection alarm equipment shall be of catalytic combustion method, membrane type galvanic cell method, semi-conductor method or any other method to automatically trigger an alarm at the preset gas concentration (hereinafter referred to as "Alarm setpoint") by detecting the change of detection element by an electrical mechanism.
- Alarm setpoint shall be a quarter or less of a lower explosive limit for combustible gases or specific inert gases, 25% for oxygen and acceptable concentration (twice the value of acceptable concentration for ammonia, chlorine and other toxic gases similar thereto with difficulty to prepare the calibration gas; the same shall apply to 1.6) or less for toxic gases, provided, however, that it shall be 0.1% or less for the Detection alarm equipment to be installed pursuant to 3.1 (6) c. In this case, Alarm setpoint shall be able to be set at any value.
- The gas alarm accuracy of Detection alarm equipment shall be $\pm 25\%$ or less for combustible gases or specific inert gases, $\pm 5\%$ or less for oxygen and $\pm 30\%$ or less for toxic gases of the Alarm setpoint.
- The delay time for the Detection alarm equipment to trigger an alarm shall be inspected by applying the alarm delay test under the provision 6.7.2 of JIS M7626 (1994) correspondingly. This inspection shall be conducted by introducing the gas 1.6 times of the concentration of the Alarm setpoint and the delay then shall be within 30 seconds, provided, however, that it shall be within one minute for specific gases which delay more than that for the structure of the Detection alarm equipment or for theoretical reasons (ammonia, carbon monoxide or any other gases equivalent thereto).
- Alarm accuracy shall not deteriorate even when there are $\pm 10\%$ fluctuations of power voltage, etc.
- The scale of indicator shall, within each scale range, clearly indicate 0 to lower explosive limit for combustible gases or specific inert gases (for those with the Alarm setpoint being low concentration, proper value of the lower explosive limit or less can be set in consideration of such Alarm setpoint), 0 to 50% for oxygen and 0 to three times the value of acceptable concentration for toxic gases.
- Once an alarm is triggered, the alarm shall, in principle, continue even upon the change of gas concentration in the atmosphere and shall stop only by its inspection or measures to be taken.
- Detection alarm equipment shall be regularly maintained in accordance with maintenance particulars described in instruction manuals or specifications. The results of maintenance shall also be recorded and retained for three years or more.
- Calibration of the reading of gas leakage detection alarm equipment for special high-pressure gas shall be carried out at least once every six months.
- Detection alarm equipment shall be checked at least once a month for triggering of an alarm upon the alarm circuit inspection and at least once a year for the proper operation by the detection and alarm inspection.

2. Construction

The construction of Detection alarm equipment shall be as follows.

- It shall have sufficient strength (element and transmission circuit being particularly durable) and shall be easy to handle and maintain (particularly for the replacement of element, etc.)
- The parts which come into contact with gases shall be made of corrosion-resistant materials or materials with sufficient anticorrosion treatment and other parts shall be finished with good coating or plating.
- For explosion proof property, it shall have passed the test under Article 44-2 of Industrial Safety and Health Act (act no. 57 of 1972).
- In the case of receiving alarms from two or more probes, receiving circuit shall be able to trigger an alarm if it is under the condition to activate the Detection alarm equipment and such point shall be identifiable even when the other triggers an alarm and activate the circuit.
- Receiving circuit shall be made easily identifiable of it being activated.
- Alarm shall trigger an alarm simultaneously with turning on or blinking of a lamp.

3. Installation place

Detection alarm equipment shall be installed as follows.

- Installation place and quantity of probes of Detection alarm equipment in the production facilities (excluding piping; the same shall apply hereinafter in 3.1) shall be in accordance with the following items:
 - In the circumference of a place where there are indoor-installed compressor, pump, reaction equipment, storage tank and other high-pressure gas equipment with high potential for gas leakage (excluding those specified in (3)) and where leaked gas is likely to accumulate: One or more per 10 meter circumference of these equipment group;
 - If those high-pressure gas equipment as referred to in (1) are installed outdoor and are close to other high-pressure equipment, walls or other structures, or are installed inside a pit or the like, a place where leaked gas is likely to accumulate: One or more per 20 meter circumference of these equipment group;
 - A place where leaked gas is likely to be accumulated in the circumference of production facilities including fire source such as a heating furnace: The number calculated by the ratio of one or more per 20 meter circumference of the place;
 - Inside an instrument room (excluding the case where measure(note) is taken to prevent penetration of leaked gas): One or more;
 - In the circumference of a group of filling ports of toxic gases: One or more; (note) In principle, the measure to prevent penetration of leaked gas shall mean either of the following:
 - To retain the pressure inside the instrument room necessary for preventing penetration of gases from outside; or
 - To raise the entrance floor to at least 2.5 meters over the ground for the instrument room only for gases heavier than air.
 - Notwithstanding the foregoing (1) to (5), the following standards shall apply to compressed hydrogen stations of Article 7-3 paragraph 2 and Article 12-2 paragraph 2 and
 - One or more inside a steel casing or inside a fireproof room in which compressor is installed, provided, however, that for such fireproof room of which inside wall dimension exceeds 10 meters, the quantity shall be one or more for every 10 meters in such length;

Related Laws and Regulations (JAPAN)

- One or more inside the dispenser case;
 - One each or more of Detection alarm equipment having one or more probes near the connection part such as the coupling between the filling hose and the container fixed onto a vehicle (see Fig.1);
 - One or more on the upper piping module of accumulator (see Fig.2);
 - One or more at a place where hydrogen is accumulated near the device to generate hydrogen such as a reformer.
- Installation place and quantity of probes for Detection alarm equipment in a repository or consumption facilities (excluding piping; the same shall apply hereinafter in 3.2) shall be in accordance with the following items:
 - In the circumference of a place where there are indoor-installed decompression equipment, storage equipment, consumption equipment (excluding part of burners, etc. which are equipped with an interlocking mechanism of pilot burner method and not likely to cause gas leakage) and other equipment with high potential for gas leakage and where leaked gas is likely to accumulate: One or more per 10 meters of the circumference of these equipment group;
 - If those equipment as referred to in (1) are installed outdoor and are close to other equipment, walls or other structures, or are installed inside a pit or the like, a place where leaked gas is likely to accumulate: One or more per 20 meter circumference of these equipment group;
 - If containers for special high-pressure gas, etc. are stored at a container depot: One or more in the circumference of a place of the container group where leaked gas is likely to accumulate;
 - Inside a cylinder cabinet: One or more.
 - The height for the probe to be installed for the facilities of 3.1 or 3.2 shall be determined in accordance with conditions such as specific gravity of the gas, environment, height of gas equipment and so on.
 - A place where alarm is triggered and lamp is turned on or blinks shall be where parties concerned are stationed and is suitable for taking various countermeasures upon an alarm.
 - In cases where forced exhaust equipment is operated around the clock in production or consumption facilities, the provisions of 3.1 and (1), (2), (3) of 3.2 shall not apply and a probe shall be installed for every inlet of forced exhaust equipment.

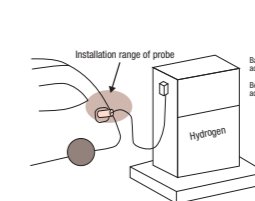

Fig.1 Example of Installation near the Connection like a Coupling

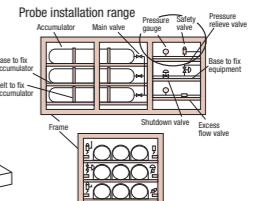

Fig.2 Example of Installation at Piping Module of Accumulators, etc.

27. Double tube for toxic gas piping

Relevant provisions

Article 6 paragraph 1 item (xxvii), Article 12 paragraph 1 item (i), Article 22 the main sentence, Article 55 paragraph 1 item (xxvi)

With regard to double tube construction for gas equipment piping of special high-pressure gas, arsenic pentafluoride, etc., sulfuric acid gas, ammonia, chlorine, chloromethyl, ethylene oxide, hydrogen cyanide, phosgene and hydrogen sulfide, the following items shall apply:

- Outer tube of the double tube construction shall have the standard inside diameter of 1.2 times or more of the outside diameter of the inner tube and material, wall thickness, etc. shall conform to the specifications under 7. Breakdown test and airtightness test, 8. Strength of high-pressure gas equipment and conduit, and 9. Standards of materials used for gas equipment, etc.
- Any of the following measures shall be taken between the inside tube and outside tube of the double tube to detect leakage of gases:
 - To install a probe of gas leakage detection and alarm equipment between the inside tube and outside tube of the double tube;
 - To install a device to detect and alarm the rise of pressure between the inside tube and outside tube of the double tube;
 - To run inert gas such as nitrogen all the time between the inside tube and outside tube of the double tube, and to install a probe of gas leakage detection alarm equipment on its outlet; or
 - To suction between the inside tube and outside tube of the double tube all the time by exhaust equipment, etc. and to install a probe of gas leakage detection alarm equipment on its outlet.

Industrial Safety and Health Act

(act no. 57 of June 8, 1972)

Latest Amendments: Act No. 78 of July 25, 2018

Chapter I General Provisions

Article 1 (purpose)

The purpose of this Act is to secure, in conjunction with the Labor Standards Act (act no. 49 of 1947), the safety and health of workers in workplaces, as well as to facilitate the establishment of comfortable working environment, by promoting comprehensive and systematic countermeasures concerning the prevention of industrial accidents, such as taking measures for the establishment of standards for hazard prevention, clarifying the safety and health management responsibility and the promotion of voluntary activities with a view to preventing industrial accidents

Chapter IV Measures for Preventing the Dangers or Health Impairment of Workers

Workers

Article 20 (measures to be taken by employers, etc.)

The employer shall take necessary measures for preventing the following dangers:

- Dangers due to machines, instruments and other equipment (hereinafter referred to as "machines, etc.")

Related Laws and Regulations (JAPAN)

- (ii) Dangers due to substances of an explosive nature, substances of a combustible nature and substances of an combustible nature
- (iii) Dangers due to electricity, heat and other energy

Chapter V Regulations concerning Machines, etc. and Harmful Substances Section 1 Regulations concerning Machines

Article 42 (restrictions on transfer, etc.)

Among machines, etc., other than specified machines, etc., which are listed in Appended Table 2, or require dangerous or harmful operations, or are used in a dangerous place, or used for preventing danger or health impairment, those defined by Cabinet Order shall not be transferred, leased or installed unless they conform to the construction code provided for by the Minister of Health, Labour and Welfare or are equipped with safety apparatus designated by the Minister of Health, Labour and Welfare.

Article 44-2 (type examination)

Of the machines, etc. as referred to in Article 42, one who has manufactured or imported a machine which is listed in Appended Table 4 and designated by the Cabinet Order shall have such manufactured or imported machine undergo the type examination to be conducted by the party registered by the Minister of Health, Labour and Welfare (hereinafter referred to as the "registered type examination agency") as prescribed by the Ordinance of the Ministry of Health, Labour and Welfare. However this provision shall not apply to the machines, etc., which have been imported, and which have undergone the examination set forth in the next paragraph.

Ordinance on Industrial Safety and Health

(ministry of labour ordinance no. 32 of September 30, 1972)

Latest Amendments: Ministry of Health, Labour and Welfare Ordinance No. 68 of April 10, 2019

Part II Safety Standards

Chapter VI Prevention of Dangers in Excavating Work, etc.

Section 2 Construction Work of Tunnels, etc.

Subsection 1 Investigation, etc.

Article 382-2 (measurement, etc. of the concentration of combustible Gas)

The employer shall, in the case of a construction work of tunnels, etc., the combustible gases are liable to be generated, designate a person charged with the measurement of the concentration of the combustible gases in order to prevent an explosion or fire and have the said person measure and record the concentration of the combustible gas at the places where the said combustible gases are liable to be generated or stagnate, every day before commencing the work for the day, after an earthquake of medium shock or heavier or when having found any abnormalities related to the said combustible gases.

Article 382-3 (Installation, etc. of automatic alarms)

The employer shall, when it is found as a result of the measurement set forth in the preceding Article that the combustible gases exist and is liable to cause an explosion or fire, install automatic alarms at necessary places for an early detection of abnormal rise in the concentration of the combustible gases. In this case, the said automatic alarms shall have system, which is able to quickly alert workers who are working around the area of the detector heads of the automatic alarms to the abnormal rises in the concentration of the said combustible gas.

2. The employer shall, as regards the automatic alarm device set forth in the preceding paragraph, check the following matters before commencing the work for the day, and immediately repair when having found any abnormalities:

- (i) Abnormalities in the measuring gauges
- (ii) Abnormalities in detector heads
- (iii) Function of the alarms

Subsection 1-3 Prevention of Explosions, Fires, etc.

Article 389-2 (measures in the case of automatic alarms sound)

The employer shall establish measures in advance that the workers concerned should take to prevent an explosion or fire due to combustible gas when the automatic alarms set forth in Article 382-3 sound, and make the said measures known to the said workers.

Part III Health Standards

Chapter I Harmful Working Environment

Article 583 (standards of concentration of carbon dioxide gas in a pit)

The employer shall ensure that the concentration of carbonic dioxide gas in the air is kept at 1.5% or less in workshop in pits. However, this shall not apply to lifesaving or danger prevention work using air respirators, oxygen respirators or hose masks.

Article 589 (workplace to be measured for work environment)

The workshops in pits prescribed by the Ordinance of the Ministry of Health, Labour and Welfare set forth in item (iv) of Article 21 of the Order shall be as follows:

- (i) Workshops in pits where carbon dioxide gas stagnates or is liable to stagnate;
- (ii) Workplace in a pit where temperature exceeds or is likely to exceed 28°C;
- (iii) Workshops in pits provided with ventilation facilities.

Article 592 (measurement, etc., of concentration of carbon dioxide gas in a pit)

The employer shall, as regards a workshop in pit set forth in item (i) of Article 589, measure concentration of carbon dioxide gas, periodically once every period within a month.

2. The provisions of paragraph (2) of Article 590 shall apply mutatis mutandis to the case that measurements pursuant to the provision of the preceding paragraph have been carried out.

Ordinance on Prevention of Anoxia, etc.

(ministry of labour ordinance no. 42 of September 30, 1972)

Latest Amendments: Ministry of Health, Labour and Welfare Ordinance No. 75 of June 19, 2018

In accordance with the provisions of Industrial Safety and Health Act (act no. 57 of 1972) and for the purpose of implementing the Act, ordinance on prevention of anoxia, etc. shall be set forth as follows:

Chapter I General Provisions

Article 1 (duties of the employer)

The employer shall make efforts to establish working methods, maintain a proper working environment and take measures necessary for preventing anoxia, etc.

Article 2 (definitions)

In this ordinance, the meanings of the terms are as defined respectively in the following items:

- (i) Oxygen deficiency: States under which the oxygen concentration in the air is less than 18%.
- (ii) Oxygen deficiency, etc.: The state defined in the preceding item or the state in which the concentration of hydrogen sulfide in the air is 10ppm or more.
- (iii) Anoxia: The symptom observed in one who has inhaled oxygen-deficient air.
- (iv) Hydrogen sulfide poisoning: The symptom observed in one who has inhaled the air in which the concentration of hydrogen sulfide is 10 ppm or more.
- (v) Anoxia, etc.: Anoxia or hydrogen sulfide poisoning.
- (vi) Hazardous work of oxygen deficiency: Those jobs to be carried out in places with the hazard of oxygen deficiency (hereinafter referred to as "oxygen-deficient place") designated in Attached Table 6 of the Enforcement Order (hereinafter referred to as "Cabinet Order") of the Industrial Safety and Health Law (cabinet ordinance no. 318 of 1972).
- (vii) Class-1 hazardous work of oxygen deficiency: The oxygen deficiency-hazard work other than class-2 hazardous work of oxygen deficiency out of the oxygen-deficiency-hazard works.
- (viii) Class-2 hazardous work of oxygen deficiency work: The work to be carried out in the oxygen-deficiency-hazard place designated in item 3-3, item 9 or item 12 of Attached Table 6 of the Cabinet Order (to be restricted to the places designated by the Minister of Health, Labour and Welfare as the places with the hazard of anoxia and hydrogen sulfide poisoning for the places designated in the said items) from among the oxygen-deficiency-hazard places.

Chapter II General Preventive Measures

Article 3 (working environment measurement, etc.)

For the workplace designated in item 9 of Article 21 of Cabinet Order, the employer shall measure the concentration of the oxygen in the air before having the workers start the day's work, providing that the concentrations of both the oxygen and hydrogen sulfide shall be measured for workplaces where class-2 hazardous work of oxygen deficiency is to be carried out.

2. When the employer has made the measurements of the oxygen concentrations in the air provided for by the preceding paragraph, he shall make a record of the items given below, every time the said measurements have been made, and shall keep the recorded results of the said measurements in custody for a period of three years.

- (i) Date and time of the measurements
- (ii) Method of measurement
- (iii) Places at which the said measurements were carried out
- (iv) Conditions of measurements
- (v) Results of the measurements
- (vi) Name of the measurer
- (vii) Outline of the measures taken for prevention of anoxia based on the results of the measurements

Article 4 (measuring instruments)

When the employer has workers engage in hazardous work of oxygen-deficiency, he shall provide the instruments necessary for measurement of oxygen concentration in the air stipulated in Paragraph 1 of the preceding Article, or shall take measures for enabling the workers to easily make use of said instruments.

Article 5 (ventilation)

The employer whose workers engage in hazardous work of oxygen deficiency shall keep the concentration of oxygen in the air at least at 18% or more in the workplace (the concentration of the oxygen shall be 18% or more, and the concentration of the hydrogen sulfide, less than 10 ppm in the case of class-2 hazardous work of oxygen deficiency) by installing an appropriate ventilating system except in cases where a ventilating system cannot be installed in order to prevent explosion or oxidation, etc., and where it is extremely difficult to install a ventilating system due to the nature of the work to be carried out.

2. The employer shall not be allowed to use pure oxygen while the workplace is ventilated conforming to the provision of the preceding paragraph.

Other Relevant Laws and Regulations

In addition to the foregoing laws and regulations, there are following relevant laws and regulations:

- Working Environment Measurement Act
- Fire Service Act
- Ship Safety Act
- Act on Maintenance of Sanitation in Buildings (building maintenance act)
- Act on Securing of Safety and Optimization of Transaction of Liquefied Petroleum Gas (liquefied petroleum gas act)
- Gas Business Act
- Act on Hot Springs

Explanation of Explosion-Proof Construction

Explosion-proof electrical equipment is currently categorized based on two types of standards.

One consists of those in accordance with "Constructional Requirements for Electrical Equipment for Explosive Atmospheres" in Ministry of Labour Notification No. 16 of 1969, and the other consists of those in accordance with "Recommended Practices for Explosion-Protected Electrical Installations in General Industries" in Ministry of Health, Labour and Welfare Labor Standards Bureau Chief Notification No. 2 of August 24, 2010, based on partial revision of the aforementioned notification.

[Constructional Requirements for Electrical Equipment for Explosive Atmospheres]

Name of explosion-proof construction and corresponding symbol for explosion-proof electrical devices satisfying certification

Type of explosion-proof construction	Symbol
Intrinsically safe explosion-proof construction	ia or ib
Flame-proof enclosure	d
Internal-pressure explosion-proof construction	f
Increased safety explosion-proof construction	e
Oil-filled explosion-proof construction	o
Non-ignition explosion-proof construction	nA or nC or nR or nL
Resin-filled explosion-proof construction	ma or mb
Special explosion-proof construction	s

Explosion-proof class type for combustible gas vapor

Explosion-proof class	Flame propagation limit (mm)
1	Over 0.6
2	Over 0.4 and 0.6 or less
3 (a, b, c, n) ^{*1}	0.4 or less

*1: For explosion-proof class 3, 3a indicates coverage for hydrogen or water gas; 3b indicates hydrogen sulfide; 3c indicates acetylene; and 3n indicates coverage for all explosion-proof class 3 combustible gas vapor.

Combustible gas vapor ignition point classification

Ignition point	Ignition temperature (°C)	Electrical device permissible temperature (°C)
G1	Over 450	360
G2	Over 300 and 450 or less	240
G3	Over 200 and 300 or less	160
G4	Over 135 and 200 or less	110
G5	Over 100 and 135 or less	80

Typical ignition points for each explosive gas explosion-proof class from "Constructional Requirements for Electrical Equipment for Explosive Atmospheres"

Temperature class Explosion-proof class	G1	G2	G3	G4	G5
1	Acetone Ammonia Carbon monoxide Ethane Acetate Ethyl acetate Toluene Propane Benzene Methanol Methane	Ethanol Isopentyl acetate Butane	Gasoline Hexane	Aceto aldehyde	
2		Ethylene Ethylene oxide			
3	Water gas Hydrogen	Acetylene			

[Recommended Practices for Explosion-Protected Electrical Installations in General Industries]

Name of explosion-proof construction and corresponding symbol for explosion-proof electrical devices satisfying certification^{*2}

Type of explosion-proof construction	Symbol
Intrinsically safe explosion-proof construction	ia or ib
Flame-proof enclosure	d
Internal-pressure explosion-proof construction	px or py
Increased safety explosion-proof construction	e
Oil-filled explosion-proof construction	o
Non-ignition explosion-proof construction	nA or nC or nR or nL
Resin-filled explosion-proof construction	ma or mb
Special explosion-proof construction	s

*2: Indicates explosion-proof construction in accordance with Recommended Practices for Explosion-Protected Electrical Installations in General Industries. Ex must be included before the symbol in the explosion-proof class.

Explosion-proof electrical device classification corresponding to maximum safe gap^{*3}

Flameproof enclosure electrical device group	Maximum safe gap (mm)
II A	0.9 or higher
II B	Over 0.5 and less than 0.9
II C	0.5 or less

Explosion-proof electrical device classification corresponding to minimum ignition current^{*3}

Intrinsically safe explosion-proof construction electrical device group	Minimum ignition current ratio (methane = 1)
II A	Over 0.8
II B	0.45 or higher and 0.8 or less
II C	Less than 0.45

*3: The electrical device group classification consists of II A, II B, and II C, but the classification method varies depending on the type of explosion-proof construction.

Combustible gas vapor classification corresponding to electrical device temperature class

Electrical device maximum surface temperature (°C)	Temperature class	Combustible gas vapor ignition temperature (°C)
450 or less	T1	Over 450
300 or less	T2	Over 300 and 450 or less
200 or less	T3	Over 200 and 300 or less
135 or less	T4	Over 135 and 200 or less
100 or less	T5	Over 100 and 135 or less
85 or less	T6	Over 85 and 100 or less

Temperature Classes of Representative Explosive Gases under the Recommended Practices for Explosion-Protected Electrical Installations in General Industries

Temperature class Explosion-proof class	T1	T2	T3	T4	T5	T6
II A	Acetone Ammonia Isobutane Ethane Acetate Ethyl acetate Toluene Benzene Methane	Isopentyl acetate Acetic anhydride Butane Propane Methanol	Hexane	Aceto aldehyde		
II B	Carbon monoxide	Ethanol Ethylene Ethylene oxide				
II C	Water gas Hydrogen	Acetylene				Carbon disulfide

Explosion-proof class example using GX-2012

Explosion-proof class: Ex ia II C T4 X

Ex: Symbol indicating explosion-proof construction in accordance with the Recommended Practices for Explosion-Protected Electrical Installations in General Industries
ia: Intrinsically safe explosion-proof enclosure

II C: Minimum ignition current ratio (methane = 1) less than 0.45
T4: Combustible gas vapor ignition point exceeds 135 °C and is 200 °C or less
X: Symbol indicating other usage precautions

	Principle and features	Construction	Output characteristics
Catalytic combustion type HW	<p>Uses the heat produced (variation in resistance of precious metal wire coil) when combustible gas is combusted on an oxidation catalyst.</p> <ul style="list-style-type: none"> The output from the sensor is virtually proportional (linear) to the gas concentration up to the lower explosive limit. Virtually unaffected by ambient temperature and humidity. Rapid response, excellent response characteristics, excellent accuracy, and repeatability 		
New ceramic type NC	<p>Uses the heat produced when combustible gas is combusted on an ultrafine particle (new ceramic) oxidation catalyst developed by RIKEN KEIKI.</p> <ul style="list-style-type: none"> Enables measurement of a wide range of concentrations from ppm to %LEL orders using a single sensor. Virtually unaffected by ambient temperature and humidity. Outstanding poisoning resistance compared to previous catalytic combustion type sensors, suffers minimal sensitivity deterioration, and offers long-term stability. 		
Semiconductor type SG	<p>Uses variations in resistance that occur when a metal oxide semiconductor comes into contact with gas.</p> <ul style="list-style-type: none"> High sensitivity with large sensor output for low concentrations. Capable of detecting a wide range of gases, including toxic gases, in addition to combustible gases. Capable of selectively detecting methane or isobutane by suppressing interference gas sensitivity Offers high resistance to harsh environmental conditions compared to other types. 		
Thermal conductivity type TE	<p>Relies on the characteristic difference in thermal conductivity for gases when the gas comes into contact with a heated element.</p> <ul style="list-style-type: none"> The output is virtually proportional (linear) to concentration up to a 100 vol% gas concentration. Allows long-term stable use, as the absence of chemical reactions such as combustion reactions eliminates catalyst degradation and poisoning. Includes a compensating element, virtually eliminating ambient environmental effects. Capable of detecting high-concentration inert gases such as argon, nitrogen, and carbon dioxide. 		
Electrochemical type ES	<p>Detects gas concentration in the form of a current generated if the gas is electrolyzed on electrodes maintained at constant potential.</p> <ul style="list-style-type: none"> Capable of detecting toxic gas with high sensitivity (e.g. arsine at 0 - 0.2 ppm). Capable of selectively detecting the target gas by selecting the potential setting. Produces a linear output, allowing accurate measurement of low-concentration gases. 		
Galvanic cell type OS	<p>Detects gas concentration in the form of a current generated when oxygen is electrolyzed on electrodes.</p> <ul style="list-style-type: none"> Allows for smaller and lighter products. No external power supply is required to operate the sensor. The output is proportional to oxygen concentration up to 100 vol%. The thermistor mounted inside the sensor performs temperature correction, eliminating virtually all temperature dependence of readings. 		
Non-dispersive infrared type DE	<p>Relies on the amount of infrared light emitted from a light source within the sensor and absorbed by the gas.</p> <ul style="list-style-type: none"> Allows accurate and consistent measurements. Provides long-term stable measurements with minimal sensitivity degradation. Offers excellent selectivity with minimal interference from coexisting gases or water vapor. Unaffected by oxygen concentration, enabling measurement even in inert gas or N₂. 		
Hydrogen flame ionization type FID	<p>Relies on variations in current due to ionization of hydrocarbon gases in a hydrogen flame.</p> <ul style="list-style-type: none"> High sensitivity with rapid response. Produces an output virtually proportional to the carbon content of hydrocarbons, totally eliminating any effects of inorganic carbon compounds. The output exhibits high linearity across the range of measurement concentrations. 		
Optical interferometric type FI	<p>Uses the property of light being refracted by gases.</p> <ul style="list-style-type: none"> Non-reliance on chemical reactions eliminates sensitivity degradation and ensures excellent long-term consistency. Capable of accurately measuring various process gas concentrations continuously Capable of measuring from 1,000 ppm orders to 100 vol% 		

SUSTAINABLE DEVELOPMENT GOALS



As a good corporate citizen, the RIKEN KEIKI Group contributes to a sustainable society through businesses based on the theme of our management philosophy of realizing environments in which people can work with peace of mind. To this end, we promote the following three sustainability activities:

• Sustainability to support the industrial infrastructure



• Sustainability in development and production of our products



• Sustainability as a good corporate citizen



Overseas Sales Bases

Region	Group company locations
North America	USA
Asia Pacific	China, Korea, Taiwan, Singapore, Malaysia
Europe	Germany



Full Support System

RIKEN KEIKI continually strives to expedite and improve its emergency response and periodic maintenance. Our comprehensive after-sales service system is supported by a team of specialist engineers.

We have an extensive servicing network of sales offices and service stations across Japan. As a manufacturer of industrial disaster prevention devices, we provide customers with year-round access to specialist service engineers for consultations on our products or after-sales services.

Region	Sales offices	Service station locations
Hokkaido	Sapporo	Sapporo
Tohoku	Iwate, Sendai	Iwate, Sendai, Tsuruoka Branch Office
Kanto, Shinetsu	Mito, Saitama, Chiba, Kanagawa	Tochigi, Mito, Tsukuba, Kashima, Saitama, Chiba, Tokyo, Yokohama, Atsugi, Niigata, Matsumoto, Kofu
Tokai, Hokuriku, Kinki	Hamamatsu, Nagoya, Yokkaichi, Kanazawa, Kansai	Hamamatsu, Nagoya, Yokkaichi Higashi, Yokkaichi, Toyama, Kanazawa, Keiji, Amagasaki, Himeji
Chugoku, Shikoku	Mizushima, Hiroshima	Mizushima, Shikoku, Higashi-Hiroshima, Hiroshima, Tokuyama
Kyushu, Okinawa	Fukuoka, Kumamoto, Oita	Fukuoka Branch Office, Tosu, Kumamoto, Oita

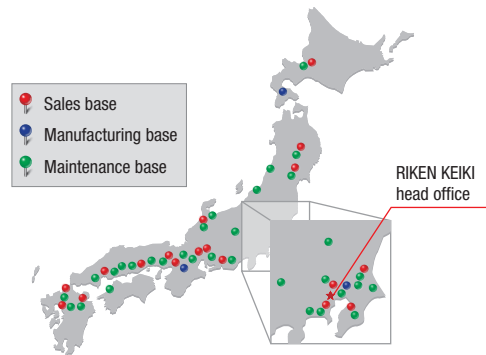

RIKEN KEIKI Co., Ltd.

Head office 2-7-6, Azusawa, Itabashi-ku, TOKYO, JAPAN 174-8744

TEL +81-3-3966-1113 FAX +81-3-3558-9110

Web <https://www.rikenkeiki.co.jp/english>

- North America United States
- South America Brazil, Argentina, Peru, Chile, Uruguay
- Asia-Pacific China, South Korea, Taiwan, Singapore, Malaysia, Indonesia, Thailand, India, Vietnam, Philippines, Australia
- Europe Germany, Greece, Netherlands, Norway, Poland, Turkey, United Kingdom
- The Middle East United Arab Emirates, Israel
- Africa South Africa
- Russia Russian Federation

* The information provided in this catalog is subject to change without notice due to product improvements.

